

* CBF STOCK OUTBOARD RACING RULES *

(Classic, Modified and PRO included)



2026

Contents

STOCK OUTBOARD RACING COMMITTEE EXECUTIVE	2
APPROVED OFFICIALS *	2
RULE * 1 * GENERAL *	2
RULE * 2 * S.O.R.C. *	2
RULE * 3 * CATEGORIES *	3
RULE * 4 * MEDALS AND CERTIFICATES *	3
RULE * 5 * RECORDS *	3
RULE * 6 * BOAT NAMES *	3
RULE * 7 * BOAT AND MOTOR ELIGIBILITY *	3
RULE * 8 * FLAGS *	4
RULE * 9 * AGE LIMITS *	4
RULE * 10 * MOTOR FUEL *	5
RULE * 11 * MEMBER QUALIFICATIONS *	5
RULE * 12 * MOTOR RESTRICTIONS *	5
RULE * 13 * MOTOR MODIFICATION *	6
RULE * 14 * SAFETY *	6
RULE * 15 * HULLS & GLOSSARY OF TERMS *	8
RULE * 16 * RUNABOUTS *	8
RULE * 17 * HYDROPLANES *	9
RULE * 18 * DELETED *	9
RULE * 19 * OTHER CLASSES *	9
RULE * 20 * STARTING *	9
RULE * 21 * CHAMPIONSHIPS *	11
RULE * 22 * COURSES *	11
RULE * 23 * POINTS *	11
RULE * 24 * OVERTAKING AND MARKS *	12
RULE * 25 * EQUIPMENT *	12
RULE * 26 * PROTESTS *	13
RULE * 27 * TECHNICAL REQUIREMENTS *	13
RULE * 28 * DISQUALIFICATION *	13
RULE * 29 * RACING NUMBERS *	13
RULE * 30 * MODIFIED OUTBOARD RULES *	13
RULE * 31 * STOCK CLASSIC RULES *	13
APPENDIXES - MOTOR SPECS	16
HIGH POINT CHAMPIONS	21
NATIONAL CHAMPIONS	23
SPECIAL RECOGNITION AWARDS	24
SPEED RECORDS	24
RULEBOOK REVISIONS	26

STOCK OUTBOARD RACING COMMITTEE EXECUTIVE

Chair/Secretary (President)	Vice-Chair	Secretary
Ethan Randle-Bragg Whitby, Ontario 365-885-1903 ethanrb@rogers.com	Summer Coulter Thorndale, Ontario 519-719-5178 summer.n.coulter@gmail.com	Gary Fraser Kearney, Ontario 705-783-3464 fzfraser@gmail.com

APPROVED OFFICIALS

* Denotes Official is in Training

To be listed on a sanction, an official must have performed duties within the last 10 years or approval from the CBF office and category Chairman is required.

Referee		Chief Scorer		Inspector - National Level	
Name	Last Used	Name	Last Used	Name	Last Used
Abel, Eric	2025	Coulson, Jana	2019	Arlt, Matthew	2019
Coulson, Sarah	2025	Dixon, Norma	2025	Dalton, Dave	2024
Dixon, Norma	2025	Goodwin, Jessica	2019	Dixon, Rob	2025
Dixon, Rob	2025	Hammond, Andrea	2025	France, Ron	2022
Fennel, Harold	2025	*Hammond, Barb	2019	Goodwin, Brian	2025
Overbury, Doug	2025	Muir, Vicki	2025	Kryskow, Paul	2019
Pietz, Heather	2025	Musca, Linda	2025	McClelland, Brent	2025
Scott, David	2025	Pietz, Heather	2025	Scott, David	2025
Utman, Spencer	2023			Snider, Greg	2024
*Murray, Dylan				Webster, Ross	2022
*Abel, Tiffany					

RULE * 1 * GENERAL *

(1-A) * The General Racing Rules shall prevail in all situations not specifically covered in the Stock Outboard Rules. All Class specifications not covered in the Stock Outboard Rules shall be taken from the current APBA Stock Outboard Rule Book

(1-B) * The eligibility rules in situations involving commercial connections are as follows;

(1-B-1) * No equipment can be registered or campaigned as the entry of any corporation or business concern. Sponsorship is allowed in the Division.

(1-B-2) * No manufacturer of motors used in Stock Outboard competition, and none of his employees, is eligible to race.

(1-B-3) * No part of this rule is to be construed as a ban on individuals who sell boats and motors through recognized dealerships.

(1-C) * The S.O. Supplement is approved as being a part of the Stock Outboard Rules, when submitted to, and approved, by the C.B.F. Racing Committee.

(1-D) * Stock Outboard Regattas in different areas or Joint Sanctioned regattas other than the National Championship may be sanctioned on the same date providing the distance between sites exceeds 400km.

(1-E) * Participants must be a member of good standing with a racing club that is recognized by the CBFNC or APBA.

(1-F) * All sanctions received by and approved for stock outboard must include All Stock and Modified Classes. Classes with 4 boats or less can combine from said program. This rule stands for any club or division requesting to include Outboard in said program. There shall be no exceptions to the rule, except for non scoring special events. If these conditions are not met the sanction shall not be approved by the Stock Outboard Racing Commission.

RULE * 2 * S.O.R.C. *

(2-A) * Racing for Stock Outboard Classes shall be conducted under the supervision of a Stock Outboard Racing Committee (referred to in the rules as the S.O.R.C). The decisions of this Committee shall be final in all matters pertaining to the administration and interpretation of the rules for these classes. This Committee shall serve as an appeal board for owners, drivers, referees, inspectors and race committee.

(2-B) * All major rule changes may be put to an email ballot. If the membership fails to return better than 60% of all the ballots then the Stock Outboard Racing Committee, shall be empowered to render its decision as final.

(2-C) * Elected positions of the SORC are two (2) year terms as follows:

(2-C-1) * Chair (President) - Even years

(2-C-2) * Vice-Chair - Odd years

(2-C-3) * Secretary - Odd years

RULE * 3 * CATEGORIES *

(3-A) * Regattas for Stock Outboard racing conducted under C.B.F. sanction shall be divided into four (4) different categories:

(3-B-1) * Closed Course *

(3-B-2) * All classes must be open to Amateurs and Professionals alike.

(3-B-3) * In each turn of a closed course race, at least one (1) turn judge shall be an experienced individual acceptable to the referee.

(3-B-4) * In a closed course race, all turn buoys should be of a highly visible colour and at least two (2) feet in height.

(3-B-5) * Any owner who permits a non-racing member to utilize his equipment in a sanctioned race shall be suspended for thirty (30) days.

(3-B-6) * A closed course race consists of at least 1 heat and heats lengths are limited to 8 km (5 miles). If no eliminations are required a two heat race is recommended. If eliminations are required a four heat race format is recommended... Elimination heat 1, elimination heat 2, Consolation heat 1, then Final heat.

(3-C) * Championship *

(3-C-1) * Same requirements as for Closed Course racing (above).

(3-C-2) * For further details, see Rule 21.

(3-C-3) * Referee and inspector for Stock Outboard National Championships to be approved by Stock Outboard Racing Committee before granting sanction.

(3-D) * Marathons *

(3-D-1) * No claims for records will be entertained.

(3-D-2) * If handicap system is utilized, S.O.R.C. must approve.

(3-D-3) * All classes must be open to Amateurs and Professionals alike.

(3-E) * Mile or kilo trials *

(3-E-1) * Kilo or mile trials shall be open to all Stock Outboard drivers that are not under driver restriction.

(3-E-2) * The same boat and motor (or equipment of same make, model and manufacture) as was used in the qualifying race must be used in the straightaway runs.

RULE * 4 * MEDALS AND CERTIFICATES *

(4-A) * The Canadian Boating Federation, in recognition of outstanding achievement in the Stock Outboard field, will present certificates as follows:

(4-A-1) * A certificate suitable for framing to each contestant who establishes a properly recognized record for his class.

RULE * 5 * RECORDS *

(5-A) * Records in the Stock Outboard Classes shall be awarded as follows:

(5-A-1) * One Mile or Kilo.

(5-A-2) * Five (5) miles in competition on surveyed courses laid out in laps measuring one (1), one and one quarter (1 1/4) or one and two thirds (1 2/3) miles.

(5-A-3) * Three (3) miles in competition on surveyed courses laid out in laps measuring one (1) mile.

RULE * 6 * BOAT NAMES *

(6-A) * The C.B.F. reserves the right to review boat names as listed on Application for Racing Numbers, and the S.O.R.C. may at its discretion refuse to issue numbers to any applicant if in its estimation a boat name is obscene or might be of such a nature as to cause embarrassment and cast any discredit on the sport.

RULE * 7 * BOAT AND MOTOR ELIGIBILITY *

(7-A) * New models, experimental or advance models, modifications to previous models, accessories or replacement parts differing in design and/or specifications from original registered motor specifications shall not be eligible for registration until such time as such motors, modifications, accessories or parts have been accepted for registration by the S.O.R.C. and until such time as they have been advertised for sale to the general public and are available for purchase through recognized sources throughout all C.B.F. Zones.

(7-B) * Guidelines to be followed will be as per current APBA inspection manual with insert pertaining to Canadian outboards not mentioned.

(7-C) * The procedure for registration of motors, parts modifications and accessories as set out in Rule (7-A) shall be as follows:

(7-C-1) * The Manufacture shall submit specifications and details on the item proposed for registration to the Vice President of the Stock Outboard Racing Committee for his approval as to the adequacy and form of the material submitted.

(7-C-2) * On approval of the S.O.R.C. Vice President, the manufacturer shall supply copies of the specifications and details to furnish one (1) copy each for the members of the Stock Outboard Committee.

(7-C-3) * The Stock Outboard Committee shall forward their recommendations to the National Office of C.B.F. who shall then supply each of its members with a copy of the specifications and details together with a ballot.

(7-C-4) * Members of the S.O.R.C. shall forward their votes to the National Office of C.B.F. for tabulation and in case of a tie vote the Stock Outboard Chairman shall cast the deciding ballot.

(7-C-5) * Final approval for use in racing of any item described heretofore shall not be given until the Vice President of the S.O.R.C. has advised the National Office of C.B.F. that he is satisfied that all provisions of Rule (7-A) of this rule have been complied with and until such time as the Chief Measurer and the National Office of C.B.F. shall have specification sheets on the item sufficient to supply the appointed inspectors at regattas.

(7-C-6) * On final approval, the National Office of C.B.F. shall advise all Racing Members of the legality of an approved item by email.

(7-D) * REPLACEMENT PARTS * The S.O.R.C. may approve only those replacement parts, modifications and accessories that a manufacturer certifies are to be stock specifications on further models of the motors on which they are to be approved for use. This rule is intended to prohibit the use in Stock Outboard Racing of any parts, modifications or accessories that are not a part of a registered motor as the purchaser may obtain it from the retail dealer. Exception, there shall be only one (1) propeller of three (3) blades or less of any make.

(7-E) * NEW MODELS * Motor specifications, including replacement parts, accessories and modifications as defined in the foregoing parts of this rule, shall be frozen for the period of a racing year, effective March 1st.

(7-F) * SPECIAL CASES * The S.O.R.C. may, according to the procedure outlined in the foregoing parts of this rule approve after the deadline date established new models, replacement parts, accessories or modifications, but such new models or previously approved models modified or using such accessories, replacement parts or modifications shall not be eligible to race against motors duly approved within the racing year freeze period. Such engines may be raced in specifically created divisions, but may not compete for prizes or for records or for championships.

(7-G) * Plastic reeds will be allowed in all modified and stock outboards.

RULE * 8 * FLAGS *

(8-A) * DEFINITIONS

GREEN	Water is open for boats, race underway.
WHITE	Final minute prior to race start, and leader has started final lap.
YELLOW	Problem on race course, continue with caution. (BLUE & WHITE flag is also used at some events)
RED	Competition is stopped, continue with caution, await further instruction.
CHECKERED	Race completed
BLACK	Return to Pits, do not leave pits, course closed

RULE * 9 * AGE LIMITS *

(9-A) * The age requirements for Stock Outboard racing shall be as follows. Age shall be determined by the birth year, excluding J classes. (Note that APBA is birth date if competing at CBF sanctioned races in the USA)

* In "J" Class, a driver may complete the racing season in which he or she reaches his or her sixteenth (16th) birth date.

CLASS	MINIMUM AGE	MAXIMUM AGE
J	9	15 *
A	14	NONE
B	14	NONE
25 SS	16	NONE
C	16	NONE
20 SS	15	NONE

D	16	NONE
45 SS	18	NONE
OSY 400	16	NONE
AXS	12	NONE

RULE * 10 * MOTOR FUEL *

(10-A) * Only motor fuel compounded of standard pump gasoline and one (1) or both of the following oils shall be used: petroleum oil, synthetic oil. Additives which produce power in excess of that produced by standard pump gasoline and petroleum base oil, shall not be permitted. The list of illegal additives includes, but is not limited to, alcohols, nitrates, and other oxygen bearing compounds. Gasohol is not a legal fuel. Any driver using fuel which does not meet the requirements of this rule shall be disqualified and automatically suspended for the remainder of the day. A driver may appeal a fuel disqualification by following the appeal procedure as covered by General Racing Rule 21. The driver must do this before leaving the inspection area, so a sample of the subject fuel can be collected with complete assurance that there has been no substitution or addition. Other tests will be performed. All costs for transportation and such tests will be assessed against the appealing member. It is advisable to have unknown gasoline and oil checked before competition. Guidelines for fuel inspection procedure and equipment are contained in the current inspection manual. Any pump gas can be used provided it comes from a gas station and can be verified.

RULE * 11 * MEMBER QUALIFICATIONS *

(11-A) * Driver Membership Qualifications:

(11-A-1) * Medical Health: All ages: It is mandatory that all drivers complete the CBF Medical Assessment Form every year when applying to CBF. This will be reviewed by CBF prior acceptance as a member.

(11-A-2) * Driving Qualification: See Rule (14-K)

(11-B) * Official Membership Qualifications:

(11-B-1) * Medical Health: It is mandatory that all officials complete the CBF Medical Assessment Form every year when applying to CBF. This will be reviewed by CBF prior acceptance as a member.

(11-B-2) * Officiating Qualification:

(11-B-2-A) * Officials used on sanctions are to come from the list of Approved Officials. This list is to be reviewed on an annual basis at the CBF annual SORC meeting. Officials who have not been active for 10 years or more are to be removed or retrained. In the event that none of the Approved Officials are available for a sanction, the SORC may temporarily approve a CBF or APBA member that in its view has satisfactory knowledge to perform the function.

(11-B-2-B) * Persons wishing to be trained as an Official are to notify the CBF or CBF Club so they can be added to the list as an Official in Training. Training takes place at sanctioned races where they work under the supervision of an Approved Official. Once the Officials they have worked under feel the trainee is qualified to be an Approved Official, they are to submit the name of the trainee to the SORC to be listed as an Approved Official.

(11-C) * All instructors at any outboard racing school shall be required to have a minimum of 5 years of racing experience to teach students of CBF sponsored racing schools. It is recommended, but not required, that all instructors have competed in a race within one year of the racing school to be eligible for the on-course instruction with a student.

(11-D) * CBF reserves the right to deny or suspend a membership and request further qualification or medical review of any member at any time.

RULE * 12 * MOTOR RESTRICTIONS *

(12-A) * An Outboard motor is defined as a complete internal combustion power and propulsion unit that can be attached to a boat and which can be lifted bodily by human power from the hull as one unit. Batteries used for ignition and starting, tachometer, throttle control and steering arrangements are accepted.

(12-B) * A Stock Motor is defined as a motor which:

(12-B-1) * Is the product of a recognized manufacture engaged in the production of outboard motors for sale to the general public.

(12-B-2) * Has been advertised and offered for sale to the public and has been available within no more than forty-five (45) days of placement of a bonafide order.

(12-B-3) * Meets all the qualifications of a Stock Motor as set out in detail in Rule (13A).

(12-B-4) * Qualifies under Rule 1.

(12-B-5) * Qualifies under the intent and spirit of this rule, which is specifically drawn to forbid the racing of special, experimental or custom built engines regardless of whether or not they shall qualify under the other sections of these rules.

(12-B-6) * The S.O.R.C. may at its discretion declare motors non stock whose manufactures have failed, at the request of the S.O.R.C. to supply information and the necessary specifications for measurements of engines and modifications, as described below.

(12-B-7) * All motors manufactured after January 1, 1954 that do not comply with the above rule are declared non stock.

(12-B-8) * Such specifications on their various models as the S.O.R.C. shall deem necessary to establish stock measurements for each model.

(12-C) * Classes and engines follow the APBA Stock Outboard rules with the following exceptions listed below. An APBA only class may be run and scored for APBA points at joint sanctioned events.

Class	Additionally Permitted Motors
15SSH	Hot Rod 15
BSH	Hot Rod 15 Hot Rod 20
BSR	Hot Rod 15
DSH	Mercury 500 series motors 1976-1989
CSR	Mercury 30H

Any previous Stock Outboard racing qualified motor can run in the Stock Classic Category under the Stock Outboard group. Boats may be grouped with like speed current classes, or on their own, or in the current class counterpart.

For info on this category see the Stock Classic Rules within this rule book.

(12-D) * COMBINING OF CLASSES - Classes of the same hull type may be combined and scored separately. For Closed Course Racing a maximum of 12 boats is permitted on the course per heat.

RULE * 13 * MOTOR MODIFICATION *

* (13-A) * For current motor technical specifications, please see the current APBA Inspection Manuals unless otherwise specified within CBF Rules.

RULE * 14 * SAFETY *

(14-A) * The throttle arrangement shall be such that when the throttle is released the venturi leading to the crank case is fully closed. The device necessary may be of any manufacture. Full throttle discs (commonly called "butterflies") are mandatory in all classes.

(14-B) * All boats must be provided with a steering wheel and an automatic device to close the throttle when released by a driver.

(14-C) * In the interests of safety, it is prohibited to lock the throttle while in competition. It is also ruled that no driver may assume a driving position that requires that he remove his hands from hand throttle. Standing in the boat, sitting on or straddling the engine are specifically prohibited. While getting on plane, drivers must keep one hand on the throttle and one foot in the cockpit.

(14-D) * The use of shock cord or elastic rope as a motor tie down is prohibited.

(14-E) * The boat must have enough buoyancy, either natural or from use of floatation gear, to float the combined hull and motor.

(14-F) * Any driver who starts an engine on shore with the propeller, shear pin, propeller nut or washer on the propeller shaft must be suspended for thirty (30) days, starting the day of the race.

(14-G) * Solid bronze swivel bushings of any make or manufacture may be used on the swivel pins of all outboard motors, in the interests of safety.

(14-H) * The race shall be stopped and restarted if a boat flips in the first turn or a driver bails out of his boat due to fire, etc. The said driver and boat is to be disqualified from that heat.

(14-I) * Considering the fact that there is no safest life jacket and helmet that will eliminate all risks, the participants are solely and ultimately responsible for selecting a suitable helmet and life jacket. To be usable, helmets are to have a CBF inspection sticker applied to helmet each year. Inspection approval means the Inspector has approved the colour, coverage and safety rating of the helmet, and it's general overall condition when inspected. If the sticker wears out, or comes off, it is up to the driver to get a new one. This inspection does not warrant the helmet safe, just that it meets the colour, coverage and safety rating requirements put forth by the CBF.

(14-I-1) * Helmets shall meet one of these rating specifications: Snell 2010 or newer (SA, M, K, CMR/CMS 2007, CMH); SFI competition 31.1 and 31.2; SFI spec 24.1 youth helmet for drivers age 16 and under. The helmet must not be older than 10 years from the date of manufacture. If no date of manufacture is listed, the certification (Example: Snell 2020) date will be used.

(14-I-2) * The upper fifty percent (50%) of the helmet must be a single color of the following: yellow or fluorescent (high visibility) yellow or lime green or orange or international orange or fluorescent red. Competitors may put writing or artwork in an area across the front to the helmet directly above the opening. This area is not to exceed 8" wide x 2" high.

(14-I-3) * Half-shell and 3/4 type helmets are not allowed.

(14-J) * All boats must be equipped with a tether activated, operational ignition cut off switch. This switch should be mounted forward of the driver and use a minimum length cord which at full extension from switch will not touch the engine. The tether must be attached to the life jacket or wrist while racing.

(14-K) * Novice drivers, and any participant that has not been an active racer in the past 15 years, must for a period of ten (10) days of sanctioned racing tape or paint a two (2) inch wide cross on their helmets. The colour to be white or black, whichever is more contrasting to the helmet colour, and the cross to extend from front tip up over the top of the helmet to the back rim of the helmet and from left ear up over the top of the helmet to the right ear. A novice driver is any participant in good standing who does not have 10 days of sanctioned racing. A new driver must be given an oral examination by the Referee or Racing Commissioner. He must show knowledge of course racing rules before being approved to enter a race. Any new driver's first day of participation in competition must consist of at least one (1) heat of racing during a sanctioned closed course event. The new driver shall drive in a position at the "rear of the pack," while being observed by the Referee and course officials. If he is not cleared for "open competition" at the end of the heat, he shall run an additional heat in the same manner until cleared by the Referee. A novice driver cannot be entered into a J-Pro class race. Competitors with less than 10 days of racing must notify the Referee at the Drivers Meeting that they are a racer with little experience and outline their experience and events attended to that point.

(14-L) * On request, all drivers will bring their racing life jackets and helmets to the Drivers' Meeting for inspection, and if necessary, a flotation test will be made on the jacket by the Race Committee.

(14-M) * The "J" classes will be given separate testing time, aside from all other classes. The heat must be stopped if a "J" driver is thrown into the water.

(14-N) * A permanently fixed fin or fins may be used on the hull. No fin or mounting hardware shall protrude beyond the vertical plane of the boat. Use of any adjustable device such as a fin, water brakes, transom lift or kick out while underway is prohibited. Engines must remain firmly clamped to the transom at all times. Loosening the clamp screws to plane the boat constitutes an adjustable kick out. The 45SS class may use a power trim system which moves the engine trim angle in or out only.

(14-O) * A yellow flag shall warn drivers of a flipped boat or other obstructions on the race course. It will be displayed from the judges stand and/or the patrol boats. Turn judges or safety personnel may stop a race with a red flag. The displaying of the red flag shall signal the stoppage of the race in the case of a medical emergency on the course or for any other reason the race committee may deem necessary. The heat may be rerun if, in the opinion of the race committee, any contestants time or position of finish has been altered, that would affect the final order of finish.

(14-P-1) * The "Cold Pit" is defined as the area the teams setup their racing outfits. This area may have free access. No propellers are permitted to be installed unless covered. No engines are to be started unless 2 safety marshals, as well as the engine starter, are required to secure a 10 foot area around the boat.

(14-P-2) * The "Hot Pit" is defined as the area teams launch and prepare to race. This area is restricted to personnel that have signed the CBF Insurance waiver only. Closed toe foot gear must be worn by personnel. If no specific "Hot Pit" area is defined, the area within 5 metres (15 feet) of the water is automatically designated the "Hot Pit".

(14-Q) * The race course shall be marked with balloons or other soft buoys that do not damage, deflect or upset boats. The S.O.R.C. recommends that all course markers be yellow in colour and that there should be a minimum of four (4) buoys in each turn.

(14-R) * The S.O.R.C. recommends that gear cases be maintained and contoured, if necessary, within class specifications. Gouges, breaks and hollows should be sanded or filled.

(14-S) * The race committee must limit the number of hydroplanes or runabouts starting in a closed course heat to twelve (12) or less.

(14-T) * Any form of Audio Communications while underway is forbidden.

(14-U) * Any boat with a non wood windshield or cowling must have a protective molding on the exposed edge.

(14-V) * All boats involved in any accident to be inspected by the inspector before being allowed back on the race course. This call can be made by the Referee and/ or the inspector.

(14-W) * Drivers must wear life jackets, helmets, eye protection and cut resistant, wrist-length and cut resistant, ankle-length pants at all times while on the water for the purpose of driving racing equipment. In closed course racing, when stopped on the course, the driver's helmet only may be removed when no other racing craft are underway anywhere on the course or when the driver's boat is tethered to a towboat. The helmet only may also be removed by drivers of stalled boats during point-to-point marathons.

Helmet restraints are recommended. All drivers must also wear impact/flak jackets, which may be worn separately or incorporated into the jacket. The impact/flak material, whether in a separate worn impact/flak jacket or incorporated into the jacket itself, will provide full coverage of the front and back of the torso. The intent is to provide full coverage of the vital internal organs. Drivers in boats equipped with reinforced cockpits are exempt from portions of this rule requiring impact/flak jackets and cut resistant clothing. The referee or inspector has the power to prohibit the use of any helmet or life jacket or cut resistant sleeves or pants that he/she determines to be potentially unsafe.

(14-X) * The Impairment rules for drivers, officials, and crew, in regards alcohol and drugs shall follow Ministry of Ontario guidelines. (0.05 BAC)

(14-X-1) * Impairment can be measured on site by race officials or a police authority on site from 1 hour before Drivers meeting scheduled time, to 30 minutes after the last heat of scheduled racing.

(14-X-2) * The consuming of alcohol or cannabis between these times in any area controlled by the CBF insurance policy is forbidden unless it is a licensed Beer Garden area.

RULE * 15 * HULLS & GLOSSARY OF TERMS *

(15-A) * AFTERPLANE; any wetted surface projecting aft of the foremost point of the gear case.

(15-B) * AMIDSHIPS; central one third (1/3) of the boat, measured in a fore and aft direction.

(15-C) * BEAM; width.

(15-D) * BOTTOM; the immersed surface of the hull shall have a neutral or positive deadrise angle when compared to the planing surface.

(15-E) * CONCAVITY; curving inward.

(15-F) * IMMERSED SURFACES; the wetted surface of the hull, including the bottom and chines from transom to bow.

(15-G) * KEEL; fore and aft centerline of the boat bottom.

(15-H) * LONGITUDINAL, LONGITUDINALLY; parallel to keel.

(15-I) * MONOPLANE; one planing surface.

(15-J) * PLANING SURFACE; the lowest immersed surface from the aft end of the immersed surface to a point 36" forward.

(15-K) * SECURELY FASTENED; does not fall out when hull is turned upside down.

(15-L) * SHEER LINE; the fore and aft curvature from stem to transom of the deck as shown in side elevation.

(15-M) * STEM; foremost point of hull.

(15-N) * TRANSOM; aftermost part of the hull in a perpendicular plane to the line of keel.

(15-O) * TRANSVERSE, TRANSVERSELY; at right angles (90) to keel.

(15-P) * TUNNEL; a concavity greater than one sixteenth (1/16) of an inch within the planing surface.

RULE * 16 * RUNABOUTS *

(16-A) * A Stock Outboard Runabout hull is defined as a racing monoplane as qualified in this rule.

(16-B) * The following table of hull dimensions shall apply:



CLASS	MOTOR	WIDTH "A"	LENGTH "B"
ASR & 15SSR	Any legal	44"	9' 5"
BSR	Sidewinder 20s / Y80	46"	10'
	Mercury / Mariner	46"	10'
25SSR	Mercury / Mariner	44"	9' 5"
	Yamato 102, 302 & 321	48"	11' 5"
	Sidewinder 20s	46"	10'
CSR & DSR	Any legal	48"	11' 5"

(16-C) * "A" Minimum beam measured at the widest point of the boat.

(16-D) * "B" Minimum length measuring centerline of hull from trailing edge of bottom to point perpendicular to stern and planing surface.

(16-E) * A Runabout hull is defined as a racing monoplane as qualified in this rule.

(16-E-1) The planing surface of a runabout shall be the lowest immersed surface at the aft end of the hull to a point 36 inches forward. Also, the planing surface shall be flat forward for 18 inches at the keel. For purpose of inspection, all measurements shall be made with a tolerance plus or minus 1/16 inch, as applicable.

(16-E-2) No part of the immersed surface may have a negative dead rise. The immersed surface may have a maximum notch of 5/8", and turning fins may also be added to the immersed surface.

(16-E-3) Runabouts shall have no through the hull air passages, vented surfaces or wings. The intent of this rule is to have the air flow over the outside surfaces of the hull.

(16-E-4) A runabout shall not have a sponson/pod protruding from the side of the boat, which interrupts the line of the side, non-trip, or bottom of the boat.

(16-F) * The minimum overall weights for Stock Runabouts shall be as used in the American Power Boat Association (APBA), except those listed below:

Runabout Class	Minimum Overall Weight in Pounds
CSR - Yamato W/ 9/16" R.PLT	415
CSR - Yamato W/ 1/2" R.PLT	405

RULE * 17 * HYDROPLANES *

(17-A) * The minimum overall racing weights of Stock Hydroplanes shall be as used in the American Power Boat Association (APBA), except those listed below:

Hydroplane Class	Minimum Overall Weight in Pounds
BSH - HR15 @ 1/2"	365
BSH - HR20 @ 1/2"	400
BSH - SW20 @ 1" W/.750 R.PLT	365 (Probationary)
DSH - 40ci Mercury	450
DSH - 44ci Mercury prior 1965	480

(17-B) * Hulls which are primarily defined as Runabout may not compete in a race advertised for Hydroplanes and vice versa.

(17-C) * On all hydroplane hulls the foremost points of the pickleforks shall have a minimum radius of 1" in one view. This minimum radius shall extend at least 45 degrees to both sides of the foremost point. At 90 degrees to this radius conforming view, the points on the picklefork will have a minimum thickness of 3/4" on the inside of the sponson and an outside picklefork dimension of 1/2". (See Figure 1)

RULE * 18 * DELETED *

RULE * 19 * OTHER CLASSES *

(19-C) * SST45 - As Per Current APBA Rule Book

(19-D) * FGPH - This class is Formula Grand Prix Hydro and is to include all current Modified motors and PRO motors up to 250cc. No minimum weight, any liquid fuel. No capsules permitted.

RULE * 20 * START AND FINISH *

(20-A) * CLOCK START

The green flag is raised and drivers may enter the race course. Drivers mill the course, and within 2 to 4 minutes the white flag is raised and instantly the green flag is lowered. At the instant the white flag is raised at all locations, the 60 second count down clock is started. Drivers approached the starting shoot and head towards the start line. Once the clock zero's the green flag is raised. Drivers crossing the start line prior to the clock hitting zero are disqualified unless a restart is ordered. The timer is started once the clock strikes zero. The clock shall be readable with 20/20 vision from in bright day light from 750' and positioned at close proximity to the start line. It shall as a minimum indicate the elapsed time in seconds of the last minute before the start. All boats must stay on plane in the starting shoot or be disqualified. Should there be a malfunction, the starter will display the yellow and

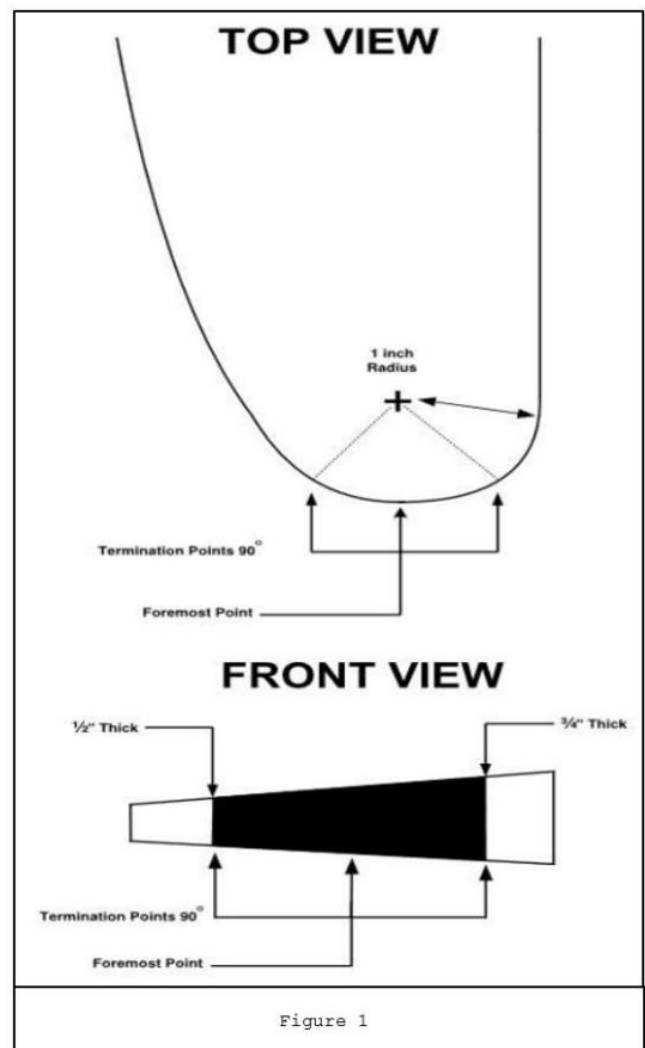

Figure 1

while flags and when in the opinion of the Referee the drivers are ready to restart, the final 60 second starting procedure shall be repeated.

(20-B) * FLAG START - ROLLING

The green flag is raised and drivers may enter the race course. Drivers mill the course, and within 2 to 4 minutes the white flag is raised. Once raised the drivers approach the starting shoot and head towards the start line as a pack at reduced speed and line up as best they can in a row. If the starter approves the line up of the pack, they drop the white flag and the race has started. If the starter does not approved the start they shall leave the white flag up and also wave the green flag to signal the pack to mill around for another run at the start line as a pack. The timer is started once the white flag is dropped.

(20-C) * FLAG START - LEMANS

Starting order of all heats to be determined by the Race Committee and announced at the drivers meeting. Boats are staged/lined up in the starting area. The white flag is raised for 1 minute. This signals that drivers may test fire their engines. After one minute the white flag is dropped and engines shall stop. Once all engines are stopped, the drivers shall signal they are ready by raising a hand. Once all drivers are ready, or 2 minutes have elapsed, the Green flag is raised for a minimum of 10 seconds and maximum of 20 seconds. At the drop of the green flag the race is started and the drivers may start their motors. Anyone starting prior, will be penalized 1 minute. The timer is started once the green flag is dropped.

(20-D) * In on water starting formats.

(20-D-1) * A boat shall not be allowed to start in any particular race or heat after the leading boat has completed one (1) lap of the race course. No boat will be allowed to leave pits. No boats other than those to enter the heat shall leave the pits after the five (5) minute gun has been fired.

(20-D-2) * All boats must stay on plane in the starting shoot or be disqualified.

(20-D-3) * Milling around, between the 500 foot buoy and the starting line shall be forbidden and all turns must be made to the left in any area while approaching the starting line and maneuvering for a start. The Referee may at his discretion alter the general plan of this rule and location of the buoy when space limitations on certain course so demand to insure good starting and the safety of the contestants.

(20-D-4) * A boat shall be disqualified which approaches the starting line at other than a right angle, or nearly so within 500 feet of the starting line. A buoy shall be located at a point 500 feet from the starting line.

(20-D-5) * Boats entering the starting shoot with less than 30 seconds remaining on the clock are committed their start run. (20-E) * For all Starting formats

(20-E-1) * The starting line shall be of sufficient length to permit all starters to start abreast without interference. Both ends of the starting line shall be plainly marked, and the flagman shall be on the line, clearly visible to all contestants. All competing boats must cross the starting line between the markers indicating the official starting line and the official stand.

(20-E-2) * An additional start can be called if, in the opinion of the Referee, the Race Committee has failed to record the number of those boats which have crossed the starting line before the official start, or if the Race Committee has acted in error.

(20-E-3) * Boats starting before the starting signal shall be disqualified unless a restart is ordered. A boat may not turn to make a restart, except as provided in the rules.

(20-E-4) * The restart is to be made immediately or as soon after as the program will permit. In the case of a restart being ordered, Yellow and White flags crossed should be displayed, followed by a one (1) minute gun and the clock.

(20-E-5) * Should the restart be postponed to a later time, a Black Postponement Flag will be shown and the boats shall return to the pits for instructions and an announcement concerning disqualifications.

(20-E-6) * Every start, unless where a restart is called, shall be final, even if there is only one (1) legal starter. In the event there is no legal starter, the Referee can restart, or call the heat completed.

(20-E-6-A) * The Race Committee may cancel a race entirely if no more than two (2) entrants indicate intent to start or only two (2) boats come to the starting line.

(20-E-6-B) * The final standing in any event necessitating qualifying heats will be determined in accordance with the point standings as accumulated in the final heat. The Race Committee of the day may use time if desired.

(20-E-6-C) * Step-up in class will not be permitted if the starting field consists of three (3) or more boats of the class for which the race was originally scheduled. If the starting field consists of fewer than three (3) boats of the class for which the race was originally scheduled, boats of the next lower piston displacement may step up; except in such instances as the Race Committee shall specifically establish a minimum boat entry for the race, and/or a statement that step-up will not be permitted. The establishment of a minimum boat entry either above or below the three (3) boat figure mentioned above must have special approval of the Race Committee.

(20-E-7) * In the event of a heat being stopped, the boat or boats that caused the race stoppage, other than jumping the gun, will be excluded from the restart.

(20-E-8) * The time of finish of each boat shall be taken when the boat's bow crosses the finish line.

(20-E-9) * All boats must complete the race to receive the checkered flag their crossing of the start/finish line. When all boats on the last lap have received the checkered flag, the black flag will be shown for all participants to return to the pits.

(20-E-10) * After crossing the finish line, a boat shall not interfere with any boat still in the race as to affect the time of such boat at the finish.

RULE * 21 * CHAMPIONSHIPS *

(21-A) * One Canadian Stock Outboard National Championship may be held per class each calendar year for full racing members of the Canadian Boating Federation only. The venue to be decided by the SORC of the CBF

(21-B) * NO NEW NOVICE DRIVER shall be allowed to join C.B.F. at a National Championship regatta and enter the regatta.

(21-C) * Championship races shall consist of two (2) final heats.

(21-D) * Qualifications: An owner may qualify without entering elimination heats if:

(21-D-1) * He/she was a Champion at the previous CBF National Championships.

(21-D-2) * In the event of eliminations, qualified boats will be determined based on position, then time up to the maximum of twelve (12), or eleven (11), in the event that the previous Champion is entered as per Rule (21-D-1).

(21-E) * There will be no sanctioned regatta within a 500 km radius of the National Championships from and including the day before up to and including the day after.

(21-F) * There must be a minimum of eight (8) registrations and bonafide starters in a class to be eligible for a National Championship.

(21-G) * CBF Outboard Supercard holders receive CBF National High Points for any legal class they participate in

RULE * 22 * COURSES *

(22-A) * In laying out courses, race sponsors are urged to take into consideration the safety of the contestants with regard to obstacles, traffic and other dangers. In so far as possible, every effort should be made to provide at least a 1,000 foot run from the starting line to the first turn and to furnish buoys of resilient material. At National Championships the distance from the starting line to the first turn buoy shall be at least 1,500 feet.

(22-B) * Please also refer to the General Racing Rules.

(22-C) * The course shall be measured in straight lines from the outside of one turning mark to the outside of the following mark.

RULE * 23 * POINTS *

(23-A) * Points for tabulation of the National High Point Championship shall be recorded by the Stock Outboard Statistician, appointed at the Annual General Meeting.

(23-B) * The High Point Champion in a given class is permitted to place the number "1" on their boat for use in that class only the following season.

(23-C) * Boats stepping up from lower classes are eligible for prizes and points.

(23-D) * When combining classes, boats are eligible for points as if running in each separate class.

(23-E) * Points will be denied any driver for a class in which he is not registered.

(23-E-1) * Drivers who are racing under a CBF Single Event Membership are not entitled to CBF points, prizes, or positions. They will count for legal boat start only. All other participants would be scored as if said racer did not exist.

(23-F) * The National high points shall be awarded the driver with the highest points in ten (10) best races. Awards will be given out based on participation in each class.

No. of participants in class	Awarded
1-3	No High Point Prize
4-7	1st place only
8+	1st, 2nd, 3rd awarded

(23-G) * To be eligible for National High Point Championship Awards, there must be a minimum of four (4) registrations at CBF Head Office by the end of the season.

(23-H) * On race day, for High Points to be awarded there must be at least three (3) legal starters for the given class. If an event wishes to raise the minimum number of legal starters, it must be stated on the sanction.

(23-I) * High Points will be awarded as follows:

Position	Standard Event	North American, National or World Championship Event
1 - First	400	800

2 - Second	300	600
3 - Third	225	450
4 - Fourth	169	338
5 - Fifth	127	254
6 - Sixth	95	190
7 - Seventh	71	142
8 - Eighth	53	106
9 - Ninth	40	80
10 - Tenth	30	60
11 - Eleventh	23	44
12 - Twelfth	17	34
13 - Thirteenth	13	26
14 - Fourteenth	10	18
15 - Fifteenth	7	14
16 - Sixteenth	5	10
17 - Seventeenth	4	8
18+ - Eighteenth plus	3	6
DNF - Did Not Finish	3	5
DQ - Disqualified	2	4
DNS - Did Not Start	1	2
Cancelled per below rule	100	200

(23-J) * If a scheduled race/class is cancelled after registration fees are paid due to weather or force majeure, the drivers in that class that are registered and attended the drivers meeting will be awarded 100 points.

RULE * 24 * OVERTAKING AND MARKS *

(24-A) * An overtaking boat shall, as long as an overlap exists, keep clear of the boat which is being overtaken. Boats in passing shall allow at least one (1) boat width of clear water between them, and the leading boat shall not alter her course so as to compel an overtaking boat to pass within the one (1) boat width limit. The overtaking boat must not alter her course until, one (1) boat length of open water exists. Should, however, an overlap exist between two (2) boats when both of them are about to pass a mark on the required side, then the outside boat must give the inside boat room to pass clear of the mark. A boat shall not bear out of her course so as to hinder another in passing to starboard.

(24-B) * An overlap may only be established when two (2) boats are on the same course of approximately the same course and the overtaking boat has no longer free choice on which side she shall pass. The inside boat may gain the right of way by establishing an overlap even after the outside boat has altered her helm for purpose of rounding the mark.

(24-C) * Any boat that fouls a buoy and doesn't return to pass the missed buoy will be disqualified. Any boat will be disqualified that forces another boat to foul a buoy or other obstruction or violates in any other way the rules governing right of way.

RULE * 25 * EQUIPMENT *

(25-A) * A starting camera or video camera must be used at all competition events.

(25-A-1) * This rule shall be interpreted that the use of a camera is purely an aid to the scorers or those who call the starts. The video footage or camera shots must be retained and available to the Driver's Rep on request until one (1) hour after the last race is completed each day. In the event of a camera or film failure, the Referee will, with the assistance of the Chief Scorer, render the decision necessary. A RESTART IS NOT REQUIRED.

(25-B) * Team Shirts or Uniforms are MANDATORY

(25-C) * For class JSH, subject to availability, CBF or APBA J Class propellers will be used. If propellers are not available drivers will supply their own propellers.

RULE * 26 * PROTESTS *

(26-A) * Protests arising from sanctioned regattas must be filed in writing with the Referee through the appointed drivers representative, not later than thirty (30) minutes after the official finish of last heat of racing on the day's schedule, or when it concerns legality of equipment, within one half (1/2) hour after inspection has been completed. The Race Committee shall then meet to settle such protests. Owners or drivers shall have the right to protest any violation of the racing rules. If the protest concerns the eligibility or legality of a motor, the complainant must post a \$100.00 protest fee to be returned if the protest is found valid and the expense of inspection and settling the protest then to be borne by the defendant. If the protest is invalid, the fee shall be awarded to the defendant as compensation for his troubles. The contestant filing a protest must be a registered participant for the regatta and be in the same class. All decisions of the Race Committee shall be final regarding violations of starting, driving and course rules. Appeals will be awarded only if a suspension of more than one (1) day is involved. Costs of such appeal to be \$100.00. Under no circumstances will an appeal be entertained if it is presented after the deadline.

RULE * 27 * TECHNICAL REQUIREMENTS *

(27-A) * Engine setups. Engine height and angle limitations and hull bottom and shapes limitations are to be taken from the current APBA Rule Book. This rule does not apply to boats running in Kilo Trials.

RULE * 28 * DISQUALIFICATION *

(28-A) * Any boat crossing the start/finish line before the clock reaches zero shall be disqualified for that heat.

(28-B) * If any on course disqualification takes place, the driver(s) involved must be notified by the referee or their representative before the next heat of racing. A twice repeated PA announcement is adequate. If the driver does not accept the disqualification, they follow the Protest/Appeals procedure.

RULE * 29 * RACING NUMBERS *

(29-A) * The racing numbers shall be a minimum of six (6) inches high with a one (1) inch stroke and shall be in strongly contrasting colours, located on the vertical sides where space permits. It is highly recommended that numbers be eight (8) inches high, with black on white or white on black format that has a one (1) inch minimum border. It is highly recommended that hydroplanes also have numbers located on foredeck/spoons on each side.

(29-B) * Boat numbers with zero's preceding are permitted on boats, however, they will be scored without zeros. It is only permitted to use these numbers if no other CBF member is using that base number. For example, if a driver requests number 007, they can only use that number if there is no 07 or 7 already registered with CBF. This is in place due to computer based scoring.

(29-C) * Upon acceptance of application registration of a racing membership, the driver will be issued a number from No 2 up. Only one number will be issued regardless the number of hulls owned or classes raced. The same number is used on all hulls. No class letters are to be used. Letters are for APBA members ONLY.

RULE * 30 * MODIFIED OUTBOARD RULES *

(30-A) * Modified Outboard classes as per APBA rules.

(30-B) * D-MOD the OMC 44.9 c.i. 2 cylinder with stock carbs be allowed to compete in the D MOD

(30-C) * The Bass/Tohatsu D Stock motor to DMH. This motor is allowed in DMH with only DSH rules NO MOD ALLOWED- No pipes of any kind are allowed to be used You can substitute Boyeson Reeds for the stock Steel Reeds and install Full butterflies supplied by Scottcraft boats or Bass Machines

(30-D) * 200ccMH & 200ccMR, the Sidewinder 15S is a legal motor when ran with no modifications.

RULE * 31 * STOCK CLASSIC RULES *

(31-A) * Purpose: Collecting Antique, Vintage, and Classic equipment, like Vintage sports car racing, has become quite popular and these enthusiasts can now have a place to race their equipment.

(31-B) * Eligible Motors: All previously approved Stock Outboard motors that have been out of production for at least twenty-five (25) years.

(31-B-1) * Motors in addition to previously qualified motors are:

DCH Allowable powerheads; (40 or 44 cubic inch)

Mercury Mark 55, 55H 58, 58A, 58H

Mercury Merc 400, 450, 500 manufactured before 1965 and fitting the bolt pattern of the 55H tower housing, without modifications.

DCH additional notes:

- A. Allow all internal powerhead parts from above engines pistons, cranks, rods, bearings, reed cages, wrist pins) as long as they are interchangeable, without modification with Mark 55 and Mark 58 series engine parts.
- B. Pistons, connecting rods and wristpins legal for 44Xs engines may be used, as long as combustion chamber cc's are not less than Mark 58H spec (22.0 cc minimum)
- C. Either Mark 55H or Mercury 44XS gear housings are legal, provided that they meet the minimum specs. Only 14:14 gears are permitted.
- D. Flat exhaust manifold plate #26922 and # 28240 exhaust manifold cover as used on Mark 55H or Mark58 are the only legal exhaust system. No tuning stack is permitted
- E. For all other specs refer to APBA stock Outboard inspection manual for Mark 55H engines.
- F. Yamato 302 gear case with nose cone is permitted on Mercury D engines. (Probation)

(31-C) * Boats: Utilities, Hydroplanes and Runabouts.

(31-D) * All Stock Outboard safety rules will apply. Driving infractions will be subject to disciplinary action by the race committee.

(31-E) * Activities: Racing. Class groups to be determined by race committee. Handicap starts may be used. Boats may be combined with current classes of comparable size and speed.

(31-E-1) * The minimum overall racing weights of Classic Classes are as follows. Classes not listed will be declared by the referee of the day.

Class	Min. Overall Weight in pounds
BCH w/ Hot Rod	390
BCH w/ Mercury	370
CCH	440
DCH	480
DCH w/40CI Mercury	450

(31-F) * If 4 boats are registered with CBFNC for the class and participate at more than one event, a High Point Award would be awarded at the end of the year. Stock Classic classes are eligible for National Championship events.

(31-G) * Racing numbers on original, restored or reproduction boats may be of original style and number/letter designation. It shall be the responsibility of the driver that the numbers are legible.

(31-H) * Classes being run would be designated by the "C" for Classic, as opposed to "S" for Stock.

Example: DCH for Classic, DSH would be the current "D" class rules. The following classes are exempted from the height portion of this rule and follow the height restrictions listed:

BCH - 0"

DCH - 1/2" below

(31-I) * In the spirit of these rules, Classic Stock/Modified/Pro motors formally used in the CBFNC Outboard GP class, would be eligible to run in a Classic Outboard GP class, hydro or runabout.

CGPH - This class is Classic Grand Prix Hydro and is to include:

All PRO legal motors prior to 1985

Previous Modified engines

Looper motors, 750cc max

Deflector motors, 66 c.i. max

4 blade max propellers

Any liquid fuel

No super or turbo chargers

No capsules will be allowed

No minimum weight

Lower units/mid housings and other parts are flexible within the spirit of the class.

(31-J) * The Stock Outboard Classic Membership is included with any CBFNC Outboard Racing Membership

(31-K) * The Vintage Membership is included with the any CBFNC Stock Outboard Racing Membership

(31-L) * If it was wanted an event could be sanction solely for a Stock Classic Racing Regatta.

(31-M) * APBA SO/MO/PRO Membership is a valid membership for racing, exhibition running or displaying at any level of a CBFNC Stock Classic / Vintage event. As normal, the participant must hold a card from the sanctioning body they wish to receive points from.

RULE * 32 * PRO OUTBOARD RULES *

(32-A) * Pro Outboard class as per APBA Rules.

(32-B) * The minimum age limit for OSY400 is 16 years of age.

APPENDIXES – MOTOR SPECS

A-1 – MERCURY MARK 30H

A-2 – MERCURY MARK 55H

A-4 – MERCURY MARK 20H

(A-1) * MERCURY MARK 30H ENGINE SPECS – Note, Skeg Detail is not to scale

CLASS C

Legal motor for Class C is: Mercury MARK 30-H

Age Requirements: Minimum 14 yrs. - Maximum None

Minimum Overall Weights: CSR - 470 lbs. CSH-435 lbs.

INSPECTION PROCEDURES

A Class "I" Inspection shall consist of the following:

- (1) Measure lower unit dimensions and check gear ratio by counting turns on prop shaft from T.D.C. to T.D.C.
- (2) Measure carburetor venturi diameter and throat diameter.
- (3) Have spark plug removed and check compression volume in cc's.
- (4) Have intake deflector cover removed and measure port (dim. "A" - dim. "A1"). Inspect ports for signs of tampering. Check for proper number of piston rings.

A Class "II" Inspection shall consist of the following:

- (1) Have powerhead removed from lower unit housing. Check gear ratio by turning driveshaft and counting turns on prop shaft.
- (2) Have tail cone nut removed and check water pump impeller for cut-off blades and "feathered" blades.
- (3) Measure lower unit dimensions.
- (4) Have crankcase and cylinder block separated.
- (5) Measure bore (dim. "G"). Check cylinder head shape for illegal "padded" block.
- (6) Have exhaust cover removed and measure "C" & "C1" dimensions. Inspect ports for signs of tampering.
- (7) Have intake deflector covers removed and measure "A" & "A1" dimensions. Inspect ports for signs of tampering.
- (8) Have carburetor removed. Measure venturi diameter and throat diameter. Inspect crankcase carburetor opening for signs of tampering.
- (9) Measure reed stop height. Measure reed block ports (dim. "N"). Check reed block passages for illegal filing and polishing.
- (10) Check crankshaft cheeks for illegal chamfering.
- (11) Check piston top shape, number of piston rings.
- (12) Have piston and rod removed and disassembled. Measure "F" dimension of piston.
- (13) Measure "L" dimension of rod.
- (14) Weigh piston assembly.
- (15) Weigh rod assembly.
- (16) Check bearings.
- (17) Weigh flywheel.

1. Any 4 cylinder mag used on a Mercury motor is legal.
2. Two types of blocks have been manufactured, both being permissible. One of these is assembled with four small intake port covers, the other with two larger port covers. Small curved or small straight port covers are permissible. The "Wizard 25" block is legal excluding all padded blocks.
3. Small grinding or deburring marks may be found in the transfer passages and are permissible if produced at the factory for the purpose of flash removal.
4. Aluminum reed block 527-16191A is a legal replacement for bronze reed blocks. Any reed block is permissible which meets the specifications.
5. Powerheads equipped with an idle bleed system also utilize two large intake port covers.
6. It is permissible to use either one or two fuel pumps. When only one pump is used, a cover plate of any manufacture may be used to cover the holes in the unused pad as long as no modification of threads or casting is made to accommodate the cover.
7. The MARK 30 and the MARK 30-H powerheads are identical and therefore interchangeable.
8. Allow the turning and balancing of pleasure engine flywheels to two lbs. weight minimum with the timing belt pulley on.
9. It is permissible to cut the flange off the top main bearing cap so a timing belt can be replaced without taking off the flywheel.
10. It shall be permissible to repair the mag adapter housing.
11. Any type seal can be used as long as it is similar to the original.
12. It shall be permissible to use the 25SS gear housing and components with 15-15 gears only. 16-21 gears are not legal. It shall be permissible to weld on to the skeg to match the original 30-H as closely as possible. It is not permissible to cut an original 30-H foot to match the 25-SS foot.
13. No polishing or balancing is permitted.

CAUTION:

- 1) Examine and tighten lower unit attaching nuts if necessary. Ensure that there are good flat mounting surfaces on both the towerhousing and the lower unit. Make sure that lower unit studs are in good condition. This lower unit requires attention because of the loads produced by the long skeg and the small mounting surface provided.
- 2) Check towerhousing at front lower unit stud attach point for cracks.
- 3) Check condition of timing belt.



GEAR CASE SKEG
(ACTUAL SIZE)

Received 10/5/04

CLASS C

ENGINE MODEL		MARK 30-H
Displacement		29.7
1	Number of cylinders	4
2	Gear ratio	15 - 15
3	Minimum compression vol. in c.c. of one cyl. to top of spark plug hole	16.0
4	Carburetor: Model No. Tillotson unless otherwise specified	AJ-49-A AJ-51-A
5	Type of lubrication	GAS OIL MIXED
6	Number and size of openings in reed block Reed Thickness .012 $\pm \frac{V}{32}$ Lower unit specifications (Minimums)	A 4.007 ± .010
		A1 3.355 ± .010
		C 4.221 ± .010
		C1 3.690 ± .010
		C1 3.569 ± .010
		E 4.581 ± .015
		F 2 7/8 ± 1/32
		G 2.112 ± .002
		J 2.125 ± .004
		L 3.719 ± .006
7	Piston material Piston weight with rings, wrist pins and fastenings Weight of conn. rod with bearings in both ends and with thrust washers Weight of flywheel Bearing specifications Note: Other standard makes of bearings of equal size and equal quality may be substituted.	N 8 PORTS 1 5/8" x 1 7/8" x 3/8"
		Q 1 1/4
		R 2 7/8
		S 1
		V 1 7/16 ± 1/16
		W 4 1/2
		X 2 23/32
		Y 2 31/32
		Z 4 3/4
		1 206 K
2 ROLLERS		
3 206 K		
4 25 ROLLERS		
5 22 ROLLERS		
6 466 306		
7 GB-912		
8 GB-98		
9 9104 K		
8	No. and size of exhaust relief holes	CAST SNOOT
9	Reed stop height	5/32 ± 1/32

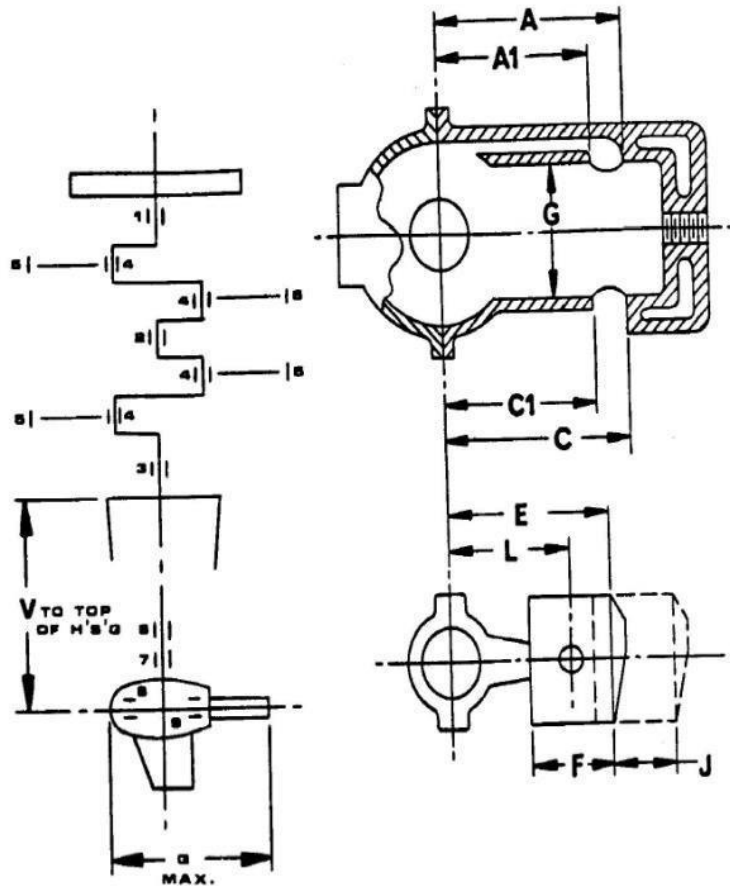

Carburetor Model No.	Venturi	Throat
AJ-49-A & AJ-51-A	13/16	15/16

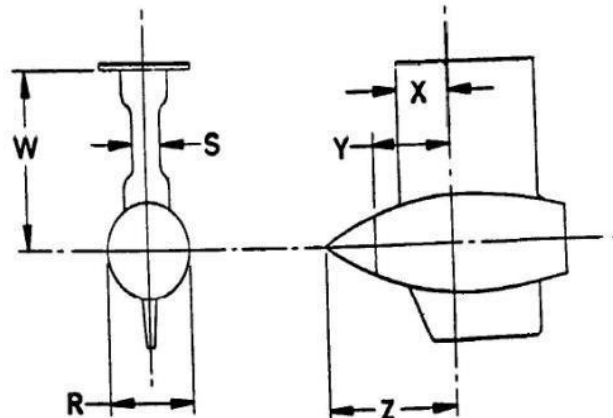

CLASS D

CAUTION:
 1) Check towerhousing at front lower unit stud attach point for cracks.
 2) Check condition of timing belt.

Legal motor for Class D is: Mercury MARK 55-H

Age Requirements: Minimum 16 yrs. - Maximum None

Minimum Overall Weights: DSR - 525 lbs. DSH - 455 lbs.

INSPECTION PROCEDURES

A Class "I" Inspection shall consist of the following:

- (1) Measure lower unit dimensions.
- (2) Measure carburetor venturi diameter and throat diameter.
- (3) Have spark plug removed and check compression volume in cc's.
- (4) Have intake deflector cover removed and measure port (dim. "A" - dim. "A1"). Inspect ports for signs of tampering. Check for proper number of piston rings.

A Class "II" Inspection shall consist of the following:

- (1) Have powerhead removed from lower unit housing.
- (2) Have tail cone nut removed and check water pump impeller for cut-off blades and "feathered" blades.
- (3) Measure lower unit dimensions.
- (4) Have crankcase and cylinder block separated.
- (5) Measure bore (dim. "G"). Check cylinder head shape for illegal "padded" block.
- (6) Have exhaust cover removed and measure "C" and "C1" dimensions. Inspect ports for signs of tampering.
- (7) Have intake deflector covers removed and measure "A" and "A1" dimensions. Inspect ports for signs of tampering.
- (8) Have carburetor removed. Measure venturi diameter and throat diameter. Inspect crankcase carburetor opening for signs of tampering.
- (9) Measure reed stop height. Measure reed block ports (dim. "N"). Check reed block passages for illegal filing and polishing.
- (10) Check crankshaft cheeks for illegal chamfering.
- (11) Check piston top shape, number of piston rings.
- (12) Have piston and rod removed and disassembled. Measure "F" dimension of piston.
- (13) Measure "L" dimension of rod.
- (14) Weigh piston assembly.
- (15) Weigh rod assembly.
- (16) Check bearings.
- (17) Weigh flywheel.

1. Any 4 cylinder mag used on a Mercury motor is legal.
2. Aluminum reed block 527-16191A1 is a legal replacement for bronze reed blocks. Any reed block is permissible which meets the specifications.
3. Any curved or straight port covers are permissible. Pistons 726-1611 A2 Std. and 726-1612 A2 .015, 726-5052 A2 .030 oversize are the legal pistons.
5. Allow the turning and balancing of pleasure engine flywheels to two lbs. weight minimum with the timing belt pulley on.
6. It is permissible to cut the flange off the top main bearing cap so a timing belt can be replaced without taking off the flywheel.
7. It shall be permissible to repair the mag adapter housing.
8. It shall be permissible to use the old prop shafts which utilize the "C" prop nut.
9. Any KA series carburetor can be used as long as the venturi stays at one inch and the throat diameter at one and one-eighth inches. This includes the KA-3A, KA-2A, and KA-1A, any needle and seat from the KA7A is legal. The allowable Carter carburetors are N 2150-S and N-2537-S.
10. Allow all stock 4 cyl. 40 ci. Mercury blocks, excluding padded blocks (larger pads than MARK 55) to be used for racing and front case to be milled out to 55-H specs so the Carter or Tillotson carburetors can be used. No porting to be done on block. Mismatched cases and blocks are permissible.
11. It is permissible to use the KG9H and Mark 40H lower housings.
12. It is illegal to use two fuel pumps.
13. It is illegal to run the short skeg foot from the KG9H or MK40H unless the skeg is welded on to match the 55H skeg as closely as possible.
14. On small port fishing blocks only add the following port width dimension. The 5/8" round hole ports to be .625 ± .020 on width only. On the 9/16" oval hold. ports to be .563 ± .020 on width only. Evidence of the ridge between the two milled holes must be present.
15. It is legal to machine the carburetor opening of the small reed blocks to match 55H specs.
16. Replacement gearcases are manufactured with the leading edge of the skeg sharpened.
17. No polishing or balancing is permitted.

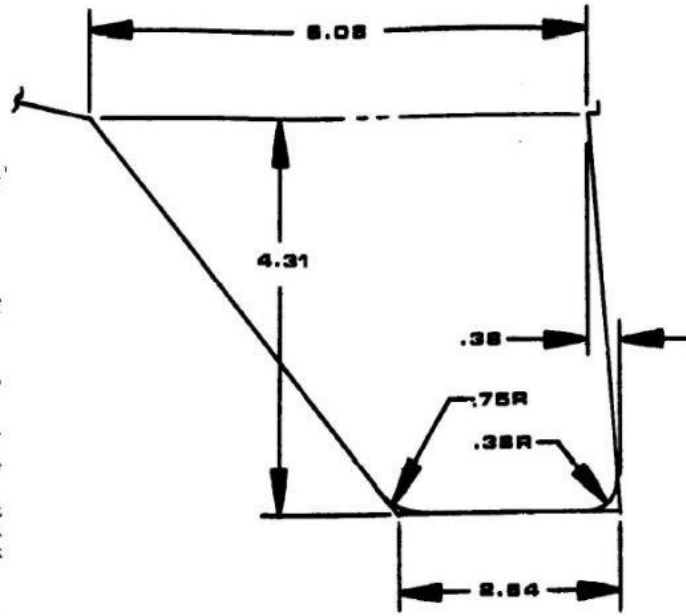

**GEAR CASE SKEG
HALF SIZE**

55-H Crankcase Carb Opening Machining Detail

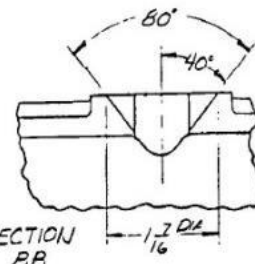
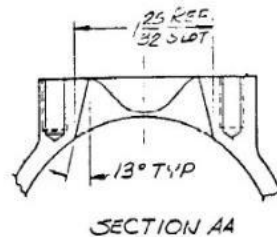
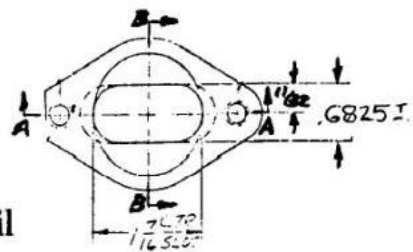

± $\frac{1}{32}$ " tolerance on carburetor opening dimensions.

Outboard Manual

ENGINE MODEL		MARK 55-H	MARK 55	MERC 300/350	
Displacement		39.6	39.6	39.6	
1	Number of cylinders	4	4	4	
2	Gear ratio	14-14	—	—	
3	Minimum compression vol. in c.c. of one cyl. to top of spark plug hole	20.5	20.5	20.5	
Carburetor: Model No. Tillotson unless otherwise specified		ANY KA CARTER N2537S	— # N2150-6	—	
Type of lubrication		GAS & OIL MIXED	—	—	
MARK 55-H BLOCK #s 808-1137 808-325 808-1320		A	4.067 ± .010	4.007 ± .010	4.007 ± .010
		A1	3.329 ± .010	3.329 ± .010	3.382 ± .010
		C	4.281 ± .010	4.221 ± .010	4.221 ± .010
		C1	3.543 ± .010	3.543 ± .010	3.596 ± .010
		E	4.587 ± .015	4.587 ± .015	4.587 ± .015
		F	2 3/16 ± 1/32	BLOCK NO.'S	
		G	2.44 ± .002	808-325	808-1087
		J	2.125 ± .004	# SOME	808-1320
		L	3.719 ± .006	808-1320	808-1321
		6 Number and size of openings in reed block		N	8 PORTS (4 @ 2 1/2" x 3/8")
Reed Thickness .012		Q	12 1/2		
Lower unit specifications (Minimums)		R	2 3/8		
		S	1 3/32		
		V	17 1/16 ± 1/16		
		W	4 1/2		
		X	3 1/16		
		Y	3 5/16		
		Z	5 1/4		
Piston material		ALUMINUM			
Piston weight with rings, wrist pins and fastenings		7.5 OZ. MIN.			
7 Weight of conn. rod with bearings in both ends and with thrust washers		6 3/4 OZ. MIN.			
Weight of flywheel		11.8-12.0 OZ. MIN.			
Bearing specifications Note: Other standard makes of bearings of equal size and equal quality may be substituted.		1	206 K		
		2	ROLLERS		
		3	206 K		
		4	25 ROLLERS		
		5	22 ROLLERS		
		6	5-8K		
		7	68-1112		
		8	68-1112		
		9	910 5 K		
8 No. and size of exhaust relief holes		CAST SMOUT			
9 Reed stop height		5/32 ± 1/32			

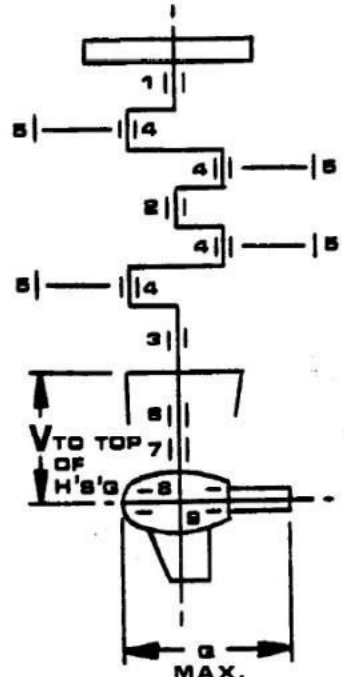
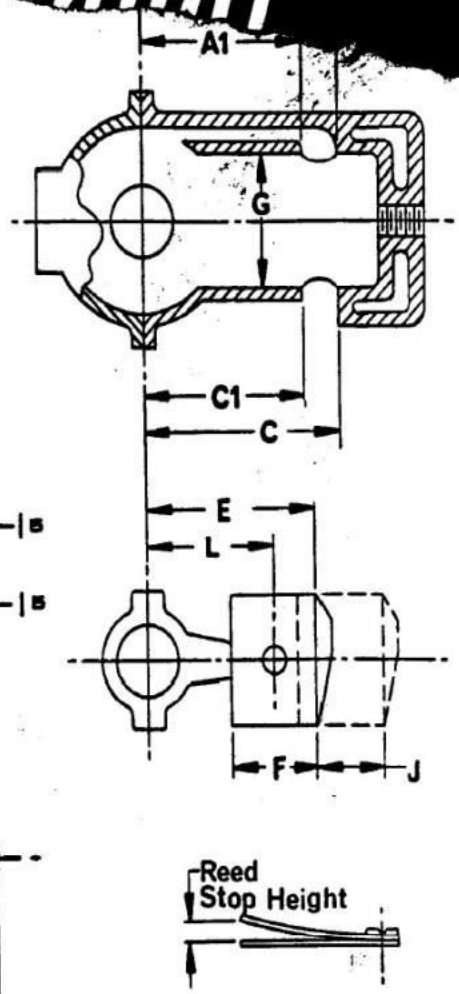

Carburetor Model No.	Venturi	Throat
KA1A, KA2A, KA3A & KA7A	1	1 1/8
CARTER N-2537 S	15/16	1 5/16

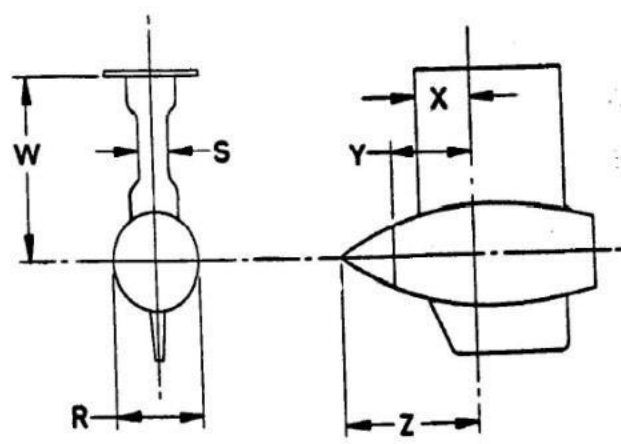

(A-3) * MERUCRY 20H - 20 CU IN 1987 STOCK SPECS

1. No Polishing or balancing is permitted
- 2 The rewind starter must be in place. It shall be permissible to use a MARK 25 rewind assembly and related parts. Any type bracket is permissible to attach rewind assembly to powerhead assembly.
3. The MARK 25 and MARK 25 electric crankcase, crankshaft, reed block (with 1" x 5/8" holes) and cylinder block may be used interchangeably with MARK 20-H parts. No modification of the MARK 25 cylinder block is permitted. The crankcase and reed block carburetor opening may be machined to duplicate the MARK 20-H crankcase opening dimension. An adapter may be added to the front of the MARK 25 crankcase to facilitate the installation of a 20-H carburetor. The distance from the carburetor mounting surface to the inside of the crankcase shall be no greater than the corresponding distance on the Mark 20-H crankcase.
4. The reed blocks with 5/8" x 1-7/32" openings are not allowed. The only reed blocks allowed have 5/8" x 1" openings. It is allowable to machine the sand cast C and D and MARK 25 reed blocks with the 1" x 5/8" openings to receive the 20-H centermain bearing race. The reed block may be drilled and tapped for the reed block bolt in another location other than the original location. The crankcase may be drilled for a reed block bolt through the fuel pump boss.
5. The "stuffed" crankcases are not permissible.
6. All 250 cc Mod, 350 cc Mod, and 25 SS gear cases are legal if they meet specifications.
7. Any KA series carburetor can be used as long as the venturi stays at 1" and the throat diameter at 1-1/8". This includes the KA3A, KA2A, KA1A, and KA7A, and any needle and seat from the KA7A is legal. Any model N Carter carburetor is legal with the 15/16" venturi and a 1-5/16" throat.
8. It is permissible to put a new keyway in the flywheel for repair. It must be 180 opposite the existing keyway. The flywheel must meet specifications.
9. It is permissible to mill or file the exhaust filler block for a good fit to the block. It is permissible to seat the filler block in a sealing or bedding compound to seal it to the block. The "Fickett" filler block is a legal replacement part.
10. For purposes of repair of welded blocks and crankcases only the following will be allowed:
 - a) A metal shim and appropriate gaskets may be added to the crankcase to bring the K dimension of the repaired crankcase within specification.
 - b) A metal shim and appropriate gaskets may be added to the repaired block to bring the port dimensions within specifications. All shims and gaskets must duplicate the dimensions of the block to crankcase gasket except thickness. The 1/32" gasket must be retained.
11. Any rod of the same manufacturer is permissible that meets the "L" dimension and minimum weight.
12. Curve port covers are not allowed.
13. Lower units are to be painted.
14. Any fuel pump is legal.
15. The Phelon ignition can be replaced with the OMC CD2 system utilizing the OMC cast steel flywheel PN 584584 / CN 513972 prepared in the same manner as the Sidewinder / Hot Rod OMC flywheel 584222. The flywheel must meet existing rule weight. No modification of the crankcase or block is allowed. The flywheel must be machined by the single source - Ed Runne.

Displacement	19.8	
Number of Cylinders	2	
Gear Ratio	15-15,16-21	
Minimum Compression Volume in cc's top of plug hole	17 cc's	
Carburetors	Venturi +/- .016	Throat +/- .016
KA1A, KA2A, KA3A, KA7A	1"	1-1/8
Carter Model N	15/16	1-5/16
A	2.246 - 2.266	
A1	1.516 - 1.546	
C	2.461 - 2.481	
C1	1.735 - 1.765	
E-E	1.700 - 1.740	
F	2.781 - 2.843	
G	2.438 - 2.472	
J	2.110 - 2.129	
K	1.804 - 1.824	
L	3.713 - 3.725	
Q	11-1/4	
R	2-1/8 +/- 1/32	
S	1 +/- 1/32	
Number and Size of Openings In Reed Block	8 Oval Ports 1 x 5/8	
Reed Material	Steel, Fiberglass	
Reed Thickness (Steel)	.012 (Steel only)	
Reed Stop Height	.125 - .187	
Piston Weight w/Rings, Wrist pins, & fastenings	7.5 oz. Min.	
Weight of Conn. Rod w/bearings in both ends & thrust washers	6.75 oz. Min.	
Weight of flywheel	4.5 lbs. Min.	

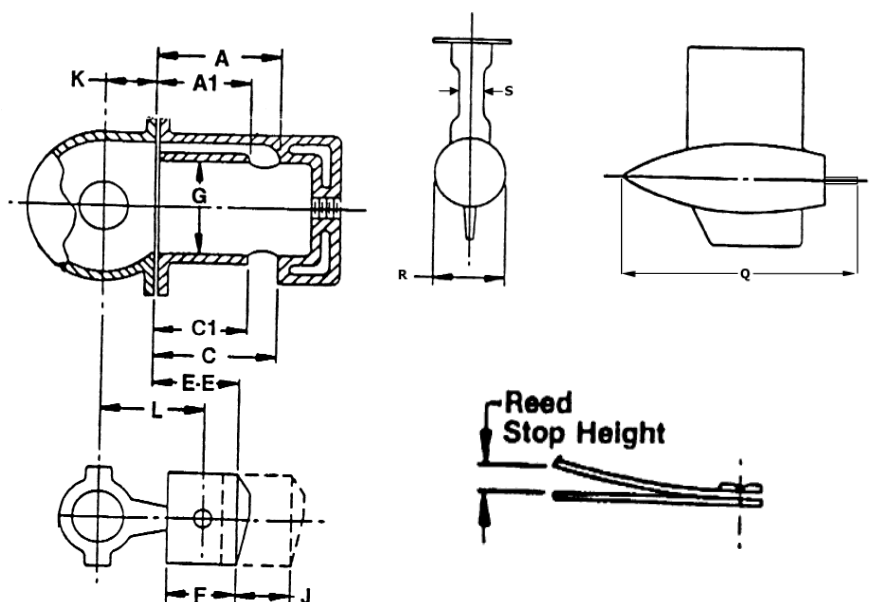

HIGH POINT CHAMPIONS

If anyone has knowledge of missing Champions, please notify the Stock Outboard Racing Committee.

Stock Outboard High Point Champions Hydroplane Classes

JSH

1980 - W Begier II,
1983 - Andrew Fralick, Brampton, Ontario, #4
1996 - Heather Knox, Mississauga, Ontario
1998 - Heather Knox, Mississauga, Ontario
2002 - Sebastien Keegan, Oshawa, Ontario
2003 - Sebastien Keegan, Oshawa, Ontario
2004 - James Armstrong, Stittsville, Ontario
2005 - Braydon Halsey, Roseneath, Ontario, #17
2006 - Braydon Halsey, Roseneath, Ontario, #17
2007 - Mike Werner Jr, Dunnville, Ontario
2008 - Maelly Bergeron #65, Rouyn-Noranda, Québec
2010 - Matthew Latter, St Lazare, Quebec
2017 - Jake Muir, Ontario
2018 - Hayden Dixon, Ontario #6
2019 - Not awarded, not enough
2020 - COVID, no racing
2021 - COVID, no racing
2022 - Tristian Coroghly, Oshawa, Ontario #113
2023 - Tristain Coroghly, Oshawa, Ontario #113
2024 - Tyler Stevenson, Roseneath, Ontario #74
2025 - Tyler Stevenson, Roseneath, Ontario #74

AXSH - Started in 2003

2003 - Jonathan Abbott, Chateaguay, Quebec
2004 - Brandon Sutton, Collingwood, Ontario 2005 - Lisa Smith, Roseneath, Ontario
2006 - Braydon Halsey, Roseneath, Ontario, #17
2007 - Emily Overbury, Sydenham, Ontario
2008 - Emily Overbury, Sydenham, Ontario,
2009 - Gaelle Bergeron, Rouyn-Noranda, Quebec
2010 - Gaelle Bergeron, Rouyn-Noranda, Quebec
2012 - Emily Overbury, Sydenham, Ontario
2013 - Damien Sutton, Ontario
2014 - David Muir, Ontario
2015 - Virginie Keegan, Oshawa, Ontario
2016 - Jessica Goodwin, Orillia, Ontario
2017 - Eric Abel, Toronto, Ontario
2018 - Jessica Goodwin, Orillia, Ontario
2019 - Jake Muir, Ontario
2020 - COVID, no racing
2021 - COVID, no racing
2022 - Hayden Dixon, Ontario
2023 - Elwood Dennis, Oshawa, Ontario
2024 - Tiffany Abel, Ajax, Ontario #7
2025 - Aidan Knox, Milton, Ontario

ASH

1980 - John Webster, Toronto, ON, #12 (Boat Count 9)
1991 - Andrew Fralick, Brampton, Ontario, #4
1994 - Blair Kants, Cambridge, Ontario, #83
1996 - Patrick Kants, Cambridge, Ontario, #93
1997 - Scott Knox, Mississauga, Ontario
1998 - Andrew Fralick, Brampton, Ontario, #4
2002 - Glen Stevenson, Roseneath, Ontario
2003 - Dan Orchard, Stratford, Ontario, #97CE
2004 - Andrew Fralick, Brampton, Ontario, #4
2005 - Dan Orchard, Stratford, Ontario, #97CE
2006 - Andrew Fralick, Brampton, Ontario, #4
2007 - Andrew Fralick, Brampton, Ontario, #4
2008 - Andrew Fralick, Brampton, Ontario, #4
2009 - Andrew Fralick, Brampton, Ontario, #4
2011 - Andrew Fralick, Brampton, Ontario, #4
2012 - Andrew Fralick, Brampton, Ontario, #4
2013 - Brandon Sutton
2014 - Rob Dixon, Bowmanville, Ontario, #5CE
2015 - Rob Dixon, Bowmanville, Ontario, #5CE
2016 - Rob Dixon, Bowmanville, Ontario, #5CE
2017 - Rob Dixon, Bowmanville, Ontario, #5CE
2018 - Graham Fralick, Milton, Ontario, #18

2019 - Graham Fralick, Milton, Ontario, #18
2020 - COVID, no racing
2021 - COVID, no racing
2022 - Eric Abel, Toronto, Ontario
2023 - Eric Abel, Toronto, Ontario
2024 - Kevin Coulson, Bracebridge, Ontario #43
2025 - Glen Stevenson, Roseneath, Ontario

BSH - New class

2017 - Ross Webster, Holland Landing, Ontario, #12
2018 - Ross Webster, Holland Landing, Ontario, #12
2019 - Evan Muir, Ontario
2020 - COVID, no racing
2021 - COVID, no racing
2022 - Ross Webster, Holland Landing, Ontario, #12
2023 - Liam Smith, Ontario #331
2024 - Jake Muir, Paisley, Ontario #47
2025 - None

CSH

1969 - Wain Trotter, Barrie, Ontario
1978 - Doug Overbury, Sydenham, Ontario
1980 - Ted Abel, Ontario (Boat Count 13)
2002 - Charlie Miller, Guelph, Ontario, #13
2004 - Bob Abbott, Chateaguay, Quebec
2005 - Bob Abbott, Chateaguay, Quebec
2006 - Mike Ounjian, Ajax, Ontario,
2007 - Scott Knox, Toronto, Ontario, #8
2008 - Brant Latter, St Lazare, Quebec
2009 - Brant Latter, St Lazare, Quebec
2010 - Erik Luksep, Toronto, Ontario, #61
2011 - Erik Luksep, Toronto, Ontario, #61
2012 - Erik Luksep, Toronto, Ontario, #61
2013 - Scott Knox, Toronto, Ontario #8
2017 - Scott Knox, Saskatchewan, #8
2018 - Brandon Sutton, Oshawa, Ontario
2019 - Rob Dixon, Port Hope, Ontario, #5CE
2020 - COVID, no racing
2021 - COVID, no racing
2022 - Wesley Hammond, Ontario
2023 - Will Hunter, Bath, Ontario #10
2024 - Rob Dixon, Port Hope, Ontario #5
2025 - Rob Dixon, Port Hope, Ontario #5

DSH

1980 - Ted Abel, Ontario (Boat Count 21)
1998 - Rob Dixon, Bowmanville, Ontario, #5CE
1999 - Rob Dixon, Bowmanville, Ontario, #5CE
2002 - Bill Keegan, Oshawa, Ontario
2004 - Ron Collins, Ontario
2005 - Dave Scott, Kanata, Ontario, #20CE
2006 - Dave Scott, Kanata, Ontario, #20CE
2007 - Steve Noury, E. Hampstead, New Hampshire, #31A
2008 - Bill Keegan, Oshawa, Ontario
2009 - Bill Keegan, Oshawa, Ontario
2010 - Steve Noury, E. Hampstead, New Hampshire, #31A
2017 - Not awarded
2020 - COVID, no racing
2021 - COVID, no racing
2024 - Wesley Hammond, Haliburton, Ontario #17
2025 - None

15SSH

1980 - Warren P Huff (Boat count 3)

20SSH

1980 - M Blackett (Mike?) (Boat count 17)
2005 - Anthony Halsey, Roseneath, Ontario
2006 - Heather Knox, Mississauga, Ontario, #14
2007 - Spencer Utman, Brockville, Ontario

2008 - James Armstrong, Stitsville, Ontario
2011 - Erik Luksep, Toronto, Ontario, #61
2012 - Paul Kryskow, Ontario
2013 - Michael Cory, Ontario
2017 - David Muir, Ontario
2018 -
2019 - Heather Pietz, Brampton, Ontario
2020 - COVID, no racing
2021 - COVID, no racing
2022 - Rob Dixon, Port Hope, Ontario, #5CE
2023 - Heather Pietz, Brampton, Ontario #14
2024 - Rob Dixon, Port Hope, Ontario #5
2025 - Rob Dixon, Port Hope, Ontario #5

25SSH - 1975 was the inception of the class
1975 - Wayne Latter, Montreal, Quebec
1980 - Gord McCrady Jr (Boat count 17)
1995 - Rob Dixon, Bowmanville, Ontario, #5CE
1997 - Rick Fralick, Picton, Ontario, #69
1998 - Rob Dixon, Bowmanville, Ontario, #5CE
1999 - Rob Dixon, Bowmanville, Ontario, #5CE

Stock Outboard High Point Champions Runabout Classes

ASR

1980 - A Gord McCrady SR
1995 - Scott Knox, Mississauga, Ontario
1996 - Blair Kants, Cambridge, Ontario, #83
1997 - Andrew Fralick, Brampton, Ontario, #4
1998 - Andrew Fralick, Brampton, Ontario, #4
1999 - Andrew Fralick, Brampton, Ontario, #4
2000 - Scott Knox, Mississauga, Ontario
2002 - Dan Orchard, Stratford, Ontario, #97CE
2003 - Andrew Fralick, Brampton, Ontario, #4
2004 - Andrew Fralick, Brampton, Ontario, #4
2005 - Andrew Fralick, Brampton, Ontario, #4
2006 - Andrew Fralick, Brampton, Ontario, #4
2007 - Jonathan Abbott, Chateaguay, Quebec
2008 - Andrew Fralick, Brampton, Ontario, #4
2009 - Andrew Fralick, Brampton, Ontario, #4
2010 - Graham Fralick, Milton, Ontario, #18
2011 - Andrew Fralick, Brampton, Ontario, #4
2012 - Jordan Elliot, Bracebridge, Ontario 2013 - Not awarded

BSR

1980 - Bob Kotar

CSR

1981 - Gerald Pemberton, Waddington, NY
1982 - Gerald Pemberton, Waddington, NY
2002 - Eric Orchard, Stratford, Ontario, #96CE
2004 - Eric Orchard, Stratford, Ontario, #96CE
2005 - Charlie Miller, Guelph, Ontario, #13
2006 - Scott Moore, Toronto, Ontario, #86
2007 - Steve Noury, East Hampstead, New Hampshire, #31
2016 - Brent McClelland, Ontario
2018 - Brent McClelland, Ontario
2019 - Brent McClelland, Ontario
2020 - COVID, no racing
2021 - COVID, no racing
2022 - Dylan Murray, Ontario #27
2023 - Dylan Murray, Ontario #27
2024 - Dylan Murray, Ontario #27
2025 - Scott Knox, Milton, Ontario

20SSR

1980 - Jim Pakeman

25SSR

1980 - A Gord McCrady SR

Modified Outboard High Point Champions - Hydroplane Classes

FAH

2000 - Heather Knox, Mississauga, Ontario
2002 - Sherry Stevenson, Roseneath, Ontario, #09

2000 - Matthew Arlt, Kingston, Ontario
2002 - Rob Keegan, Oshawa, Ontario
2004 - Christopher Sutton, Collingwood, Ontario
2005 - Rob Keegan, Oshawa, Ontario
2006 - Tony Halsey, Roseneath, Ontario, #16
2007 - Jesse Loukes, Roseneath, Ontario, #55
2008 - Rick Fralick, Picton, Ontario, #69
2009 - Ed Tokarski, Waterdown, Ontario, #5
2010 - Rick Fralick, Picton, Ontario, #69
2011 - Ed Tokarski, Waterdown, Ontario, #5
2012 - Will Hunter, Gravenhurst, Ontario
2013 - Andrew Fralick, Brampton, Ontario, #69
2014 - Andrew Fralick, Brampton, Ontario, #69
2015 - Andrew Fralick, Brampton, Ontario, #69
2016 - Andrew Fralick, Brampton, Ontario, #69
2017 - Andrew Fralick, Brampton, Ontario, #69
2018 - Andrew Fralick, Brampton, Ontario, #69
2019 - Andrew Fralick, Brampton, Ontario, #69
2020 - COVID, no racing
2021 - COVID, no racing
2022 - Class Closed, 25XS moved to BSH.

CMH

2005 - John Greer, Ontario
2006 - Joe Pemberton, Waddington, NY
2008 - David Scott, Kanata, Ontario
2020 - COVID, no racing
2021 - COVID, no racing
2022 - Not enough entries
2023 - Mitch Knapton, Ontario
2024 - Mitch Knapton, Ontario
2025 - Mitch Knapton, Ontario

DMH

2002 - Doug Overbury, Sydenham, Ontario
2004 - Ron Collins, Barrie, Ontario
2005 - Dave Scott, Kanata, Ontario, #20CE
2006 - Dave Scott, Kanata, Ontario, #20CE
2007 - Bill Keegan, Oshawa, Ontario, #55
2008 - David Scott, Kanata, Ontario
2020 - COVID, no racing
2021 - COVID, no racing
2022 - Wesley Hammond, Haliburton, Ontario
2023 - Danny Potts, Sydenham, Ontario
2024 - None
2025 - Danny Potts, Sydenham, Ontario

FEH

1980 - Vince Gresko
1981 - Bob Abbott, Chateaguay, Quebec
1982 - Bob Abbott, Chateaguay, Quebec
2004 - Wayne Izzo, New York
2006 - Rolf Flenti, Ontario
2007 - Dave Dalton, Perth, Ontario, #65

Modified Outboard High Point Champions Runabout Classes

CMR

2002 - Eric Orchard, Stratford, Ontario, #96CE
2004 - Eric Orchard, Stratford, Ontario, #96CE
2005 - Eric Orchard, Stratford, Ontario, #96CE

Classic Outboard High Point Champions Hydroplane Classes

BCH - 2006 was the inception of the class as BCH, formally BSH

1980 - Tom Boulter, Belleville, Ontario, #8CE (Boat Count 18)
1992 - Rob Dixon, Bowmanville, Ontario, #5CE
1993 - Rob Dixon, Bowmanville, Ontario, #5CE
1994 - Rob Dixon, Bowmanville, Ontario, #5CE
1995 - Rob Dixon, Bowmanville, Ontario, #5CE
2000 - Rob Dixon, Bowmanville, Ontario, #5CE
2002 - Glen Stevenson, Roseneath, Ontario
2003 - John Webster, Scarborough, Ontario, #12
2004 - not awarded (Spencer Utman, Brockville, Ontario, single entry)

2005 - not awarded (Dave Greer, single entry)
2006 - Renamed to B Classic Hydro
2006 - David Greer, Ontario
2007 - Graham Fralick, Milton, Ontario
2008 - Graham Fralick, Milton, Ontario
2012 - Will Hunter, Gravenhurst, Ontario
2013 - Will Hunter, Gravenhurst, Ontario
2014 - Rob Dixon, Bowmanville, Ontario, #5CE
2015 - Rob Dixon, Bowmanville, Ontario, #5CE
2017 - Kevin Coulson, Bracebridge, Ontario #43
2020 - COVID, no racing
2021 - COVID, no racing
2022 - Kevin Coulson, Bracebridge, Ontario #43
2023 - Kevin Coulson, Bracebridge, Ontario #43
2024 - Kevin Coulson, Bracebridge, Ontario #43

DCH

2004 - Doug Overbury, Sydenham, Ontario
2005 - Mike Ounjian, Ajax, Ontario, #21CE
2006 - Mike Ounjian, Ajax, Ontario, #21CE
2007 - Doug Overbury, Sydenham, Ontario

Formula Outboard (PRO) High Point Champions - Hydroplane Classes

J Pro Hydro

2002 - Daniel Orchard, Stratford, Ontario, #97CE

OSY400

2003 - Scott Knox, Mississauga, Ontario, #8
2006 - Scott Knox, Toronto, Ontario, #8
2008 - Brant Latter, St Lazar, Quebec
2012 - Kristian Luksep, Toronto, Ontario, #62
2014 - Spencer Utman, Brockville, Ontario
2016 - Erik Luksep, Toronto, Ontario, #61
2017 - Paul Coulter, Ontario
2019 - Paul Coulter, Ontario
2020 - COVID, no racing
2021 - COVID, no racing
2022 - Andrew Fralick, Brampton, Ontario, #4
2023 - Andrew Fralick, Brampton, Ontario, #4
2024 - Andrew Fralick, Brampton, Ontario, #4
2025 - Andrew Fralick, Brampton, Ontario, #4

Formula Outboard (PRO) High Point Champions - Runabout Classes

C Service R

1980 - Jeff Lytle of Toronto ON
1983 - Jeff Lytle of Toronto ON

NATIONAL CHAMPIONS

If anyone has knowledge of missing Champions, please notify the Outboard Racing Committee.

Stock Outboard National Champions Hydroplane Classes

JSH

1981 - Tie between David and Gordon Cobey at Richibucto, New Brunswick
1994 - Heather Knox, Campbellford ON, at Sault Ste. Marie ON

AXSH

2003 - Andrew Fralick 4, Brampton ON, @ Long Sault, ON only time awarded

ASH

1955 - John Webster, Toronto, Ontario
1956 - K Cavanaugh, Perth, Ontario
1957 - John Webster, Toronto, Ontario
1958 - Jim Benson, Harrison Lake,
1959 - K Cavanaugh, Perth, Ontario
1960 - John Webster, Toronto, Ontario
1961 - John Webster, Toronto, Ontario
1962 - Jim Toohey, Dunnville, Ontario
1963 - Len "Canoogie Rebel" Vigodda
1964 - Spike Burns "Team Ardron & Burns",
1965 - Len "Canoogie Rebel" Vigodda,
1966 - John Webster, Toronto, Ontario
1967 - Jim Toohey, Dunnville, Ontario
1968 - Spike Burns, Oshawa, Ontario
1969 - Ron France, Toronto, Ontario
1970 - Ron France, Toronto, Ontario
1971 - John Webster, Scarborough, Ontario
1972 - Ron France, Toronto, Ontario
1973 - Jim Toohey, Dunnville ON, at Halifax, NS
1974 - Tom Bain, at Peterborough, Ontario
1975 - Ron France, Toronto ON, at Welland ON
1976 - Jim Toohey, Dunnville ON, at Pierrefonds QC
1977 - Ron France, Toronto ON, at Port Perry ON
1979 - Shawn Deugo, Pakenham ON, at Sydenham ON
1983 - Tom Boulter 8CE, Belleville, ON @ Peterboro ON
1993 - Blair Kants #83, Cambridge, ON
1996 - Patrick Kants #93, Cambridge, ON
2003 - Andrew Fralick 4, Brampton ON, at Long Sault ON

BSH

1976 - Rick Fralick #69, Picton ON
1980 - Rick Fralick #69, Picton ON
1995 - Rob Dixon 5CE, Bowmanville ON @ Sault Ste Marie ON

25SSH

1995 - Rob Dixon 5CE, Bowmanville, ON @ Sault Ste Marie, ON

Stock Outboard National Champions Runabout Classes

ASR

1955 - Billy Sampson, Akron, Ohio, at Barrie, Ontario
1956 - Billy Schumacher, Seattle WA, @ Smith Falls ON
1957 - Keith Cavanaugh, Perth ON, @ London, Ontario
1958 - Jim Benson, Seattle WA, at Harrison Lake
1959 - K Cavanaugh, Perth, Ontario
1960 - Jim Toohey, Dunnville ON, #41, at Caledonia ON
1961 - Jim Toohey, Dunnville, Ontario, #41
1962 - Jim Toohey, Dunnville, Ontario, #41
1963 - Steve Ware, Toronto, Ontario
1964 - Jim Toohey, Dunnville, ON, #41, @ Richibucto NB
1965 - D Tillotson, Niagara, Ontario
1966 - Jim Toohey, Dunnville, Ontario, #141
1967 - Spike Burns, Oshawa, Ontario
1968 - Spike Burns, Oshawa, Ontario
1969 - Spike Burns, Oshawa, Ontario
1970 - John Puestow, Fawcette, Wisconsin
1971 - Jack Wilson, Brockville, Ontario - At this point the location is the place of the race and not the place of the driver
1972 - Jim Toohey, Dunnville ON, at Oak Lake, Ontario
1973 - Jim Toohey, Dunnville ON, at Halifax, NS
1975 - Ron McNeil, Welland, Ontario
1976 - Jim Toohey, Dunnville ON, at Pierrefonds, QC
1977 - Mike Werner, Dunnville ON, at Port Perry, ON
1978 - Ken France, Toronto ON, at Quyon, QC
1979 - Mike Werner, Dunnville ON, at Sydenham, ON
1981 - Gord McCrady Sr, Richibucto, New Brunswick
2003 - Andrew Fralick, Brampton ON, at Long Sault, ON

Classic Outboard National Champions Hydroplane Classes

DCH

2007 - Doug Overbury, Sydenham, Ontario

Formula Outboard (PRO) National Champions Runabout Classes

F500R

1978 - Jeff Lytle of Toronto ON, at Gravenhurst ON

CRR

1974 - Wilhelm (Willy) Kersjes of Ottawa ON, at Beloit QC in a Desilva/Cresent

SPECIAL RECOGNITION AWARDS

If anyone has knowledge of missing details or award winners, please notify the Outboard Racing Committee.

Trophy Name: Wallace Wood Memorial Award

Reason: Awarded to the driver with the most points in any one class of the stock outboard division.

Who was Wallace Wood: ??

Year First Handed Out: ??

Recipients: 1983 - Andrew Fralick, Brampton, Ontario - JSH

Trophy Name: The Stevenson Award

Reason: Outstanding Involvement in the Stock Outboard Division

Who are the Stevenson's:

Year First Handed out: 1994

Recipients:

1994 - Rick Fralick, Picton, Ontario

1995 - Norma Dixon, Bowmanville, Ontario

1996 - Andrew Fralick, Brampton, Ontario

1997 - Pat Kants, Cambridge, Ontario

1998 - John Webster, Toronto, Ontario

1999 - Doug Overbury, Sydenham, Ontario

2000 - Chris Wrong, Ontario

2001 - Eric Orchard, Stratford, Ontario

2002 - John Knox, Campbellford, Ontario

2003 -

2004 - Diane Godin, Chateaguay, Quebec

2005 - Jim Misener, Bowmanville, Ontario

2006 - Mike Ounjian, Ajax, Ontario

2007 -

2008 -

2009 - Bruce Bain, Richmond, Ontario

2010 - Heather Knox, Mississauga, Ontario

2011 -

2012 -

2013 - Jim Hunter, Gravenhurst, Ontario

2014 - Dixon Family, Bowmanville, Ontario

2015 - Ron France, Grimsby, Ontario

2025 - Sarah Coulson, Ontario

Trophy Name: Best Race of the Year

Reason: Awarded to Best Outboard Race Held In Canada

Who was ??:

Year First Handed Out: ??

Recipients:

2002 - Thunder on the Nanticoke, Waterford, Ontario - TORC

2004 - Almonte Regatta, Almonte, Ontario - OVPBC

2005 - Long Sault Regatta, Long Sault, Ontario - ECORC

2007 - Thunder on the Nanticoke, Waterford ON - TORC

2008 - Mississippi Classic, Carleton Place ON - OVPBC

2009 - Mississippi Classic, Carleton Place ON - OVPBC

2010 - Dunnville Thunder on the Grand, Dunnville, ON - TORC

2011 - Gravenhurst, Ontario - TORC

2017 - Gravenhurst, Ontario - TORC

2020 - Tweed, Ontario - TORC

2023 - Haliburton, Ontario - TORC

2024 - Haliburton, Ontario - TORC

2025 - Erinsville, Ontario - OVPBC

Trophy Name: Jack Abel Memorial Award

Reason: unknown Who was Jack Abel:

Year First Handed out: ?

Recipients:

1999 - Fralick Family, Rick-Brenda-Andrew-Graham, Cheltenham, Ontario

2002 - Glen Stevenson, Roseneath, Ontario

2004 - Dave Scott, Kanata, Ontario

2005 - Doug Overbury, Sydenham, Ontario

Removed from CBF and passed to TORC to hand out

2008 - Trophy moved from CBF to TORC at request of Abel family

Trophy Name: Ronald G. Robinson Award

Unknown details, but it existed.

Trophy Name: Eric Wolfe Trophy

Reason: Presented in memory of a good friend and fierce competitor

Who Was Eric Wolfe: Was #19N in class CSH and DSH

Year First Awarded: ?

Recipients:

1980 - M. Hewitt

1981 - Doug Overbury, Kingston, Ontario

2003 - Bob Abbott "Race Director", Diane Godin

"Chief Scorer" and Bruce Overbury "Pit Manager"

2005 - Gerald Pemberton, Waddington, New York

2006 - Dave Scott, Kanata, Ontario

2007 - Robin Shane, USA

2008 - Eric Armstrong, Stittsville, Ontario

2009 - Steve Noury, East Hampstead, NH, USA

2010 - Graham Fralick, Milton, Ontario

2011 - Erik Luksep, Toronto, Ontario

2024 - Dylan Murray, Ontario

2025 - Tammy Everitt, Ontario

Trophy Name: Outboard Rookie of the Year

Reason: Best new driver

Year First Awarded: 2008

Recipients:

2008 - Scott Toole, Oshawa, Ontario, Mod U

2011 - David Elsey, Burlington, Ontario, 25SSH

2024 - Ethan Randle-Bragg, Ajax, Ontario ASH

2025 - Ethan Steele, Toronto, Ontario JSH

Trophy Name: Frank Dashwood Award

Reason: Highest Points in the Formula Outboard Division

Who was Frank Dashwood:

Year First Awarded:

Recipients: Unknown

SPEED RECORDS

KILO Speed Records

Stock Outboard - Hydroplanes

JSH William Begier Jr. Sept. 1978 Welland 36.337

ASH Tom Bain Sept. 1978 Welland 59.153

BSH Tom Boulter Sept. 1978 Welland 68.436

CSH Ted Abel/E.Abel Oct. 1983 Welland 70.112

DSH David Hull Oct. 1983 Welland 77.550

15SSH S. Deugo Sept. 1976 Welland 56.596

20SSH Gary Lafrance Oct. 1983 Welland 62.948

25SSH Larry Burns Hydro Oct. 1976 Welland

63.860

Stock Outboard - Runabouts

ASR J. Toohey Sept. 1976 Welland 49.665
BSR Skip Hartman Oct. 1983 Welland 64.519
CSR J. Rawleigh Sept. 1976 Welland 60.656
20SSR Normand Bachand Oct. 1983 Welland 63.559
25SSR Skip Hartman Oct. 1983 Welland 59.735
SSR D. Summerfeldt Sept. 1967 61.966
Formula Outboard (PRO) - Hydroplanes
250ccH Neal Larose Oct. 1983 Welland 87.730
350ccH Doug Thompson Oct. 1972 85.709
500ccH Greg Hall Sept. 1978 Welland 93.392
750ccH Roy Alexander Oct. 1976 Welland 86.375
1100ccH Steve Alison Oct. 1976 Welland 87.220

Closed Course Records

*** 1 MILE - 3 LAPS ***

*** STOCK OUTBOARD ***

ASH Blair Kants Aug. 1993 Dunnville 44.331

*** 1 2/3 MILE - 3 LAPS ***

*** STOCK OUTBOARD ***

JSH Ken France Sept. 1976 32.585

ASH Ron France Sept. 1976 53.747

BSH Tom Boulter Sept. 1976 58.004

CSH R. Ogier July 1964 58.441

DSH Eric Wolfe Sept. 1976 67.134

25SSH J.L. Bachand Sept. 1976 53.989

ASR Bev Hall Sept. 1976 43.228

F44H Vince Gresko Sept. 1978 Welland 77.489
Grand Prix Roy Alexander Sept. 1978 Welland
96.331
FU(OZ) D.O'Dea/G.Andrews Jr. Oct. 1983 Welland
132.029
C Service H K.Williams/A.Williams Oct. 1976
Welland 57.433
Formula Outboard (PRO) - Runabouts
500ccR Willy Kersjes Oct. 1972 67.598
C Service R A.Williams/K.Williams Oct. 1976
Welland 54.003

BSR Charles Faucher Sept. 1976 50.195

*** FORMULA OUTBOARD ***

250ccH C.Gougeon/A.Hebert July 1972 64.523

350ccH Doug Thompson July 1972 69.189

500ccH Robert Mercier July 1970 75.853

C Service R Mannfred Hagmann July 1965 47.195

350ccR J.N. Hebert July 1965 57.142

500ccR C.W. Howgate July 1972 62.702

Grand Prix Roy Alexander Aug. 1984 84.826

RULEBOOK REVISIONS

This rulebook was released: January 21, 2026

This rulebook was amended: N/A

Amendment: N/A

Below are rules affected in the 2025 Rulebook to create this 2026 Rulebook.

For prior changes, see prior rulebooks.

Rules deleted: None

Rules altered: Stock Outboard Racing Committee Executive, Approved Officials, 14-I-1, 16-F, 17-A

Rules added: 14-X, 14-X-1, 14-X-2, 23-J, 28-B,